

# OJON Indoor type Disconnectors

Catalogue

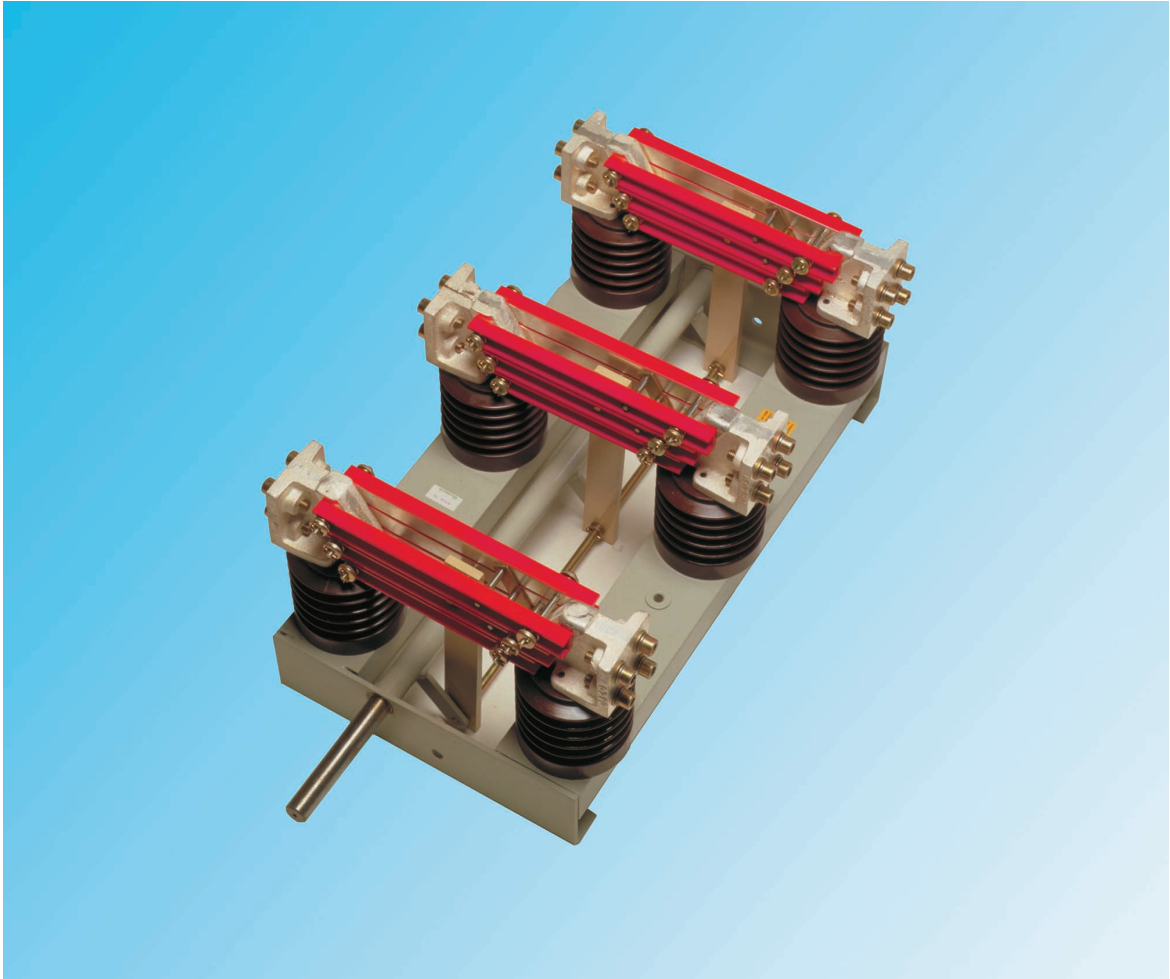

Provided by Northeast Power Systems, Inc.  
[www.nepsi.com](http://www.nepsi.com)

**ABB**

# ABB OJON Indoor type Disconnectors

1...24 kV

## Contents

General .....	3
Technical data and ordering information	
— Standards and Operating Conditions .....	4
— Installation .....	4
— Ordering Information .....	4
— Rated Voltages and Voltage Withstand Levels .....	4
— Technical Data .....	5
Accessories	
— Selection table .....	6
— Earthing knives .....	7
— Disconnector Control .....	7
— Motor Operation Mechanism UEMC 40_ .....	7
— Operating Arm .....	7
— Manual Operating mechanism, alternative A, OJO-ZA 1 .....	7
— Manual Operating mechanism, alternative B, UEKO 2C3 .....	8
— Support bearing .....	9
— Accessories to be ordered separately .....	9
— Auxiliary switches .....	10
— Interlocking .....	12
— Locking device .....	12
— Locking coil .....	12
— Extention shaft and support bearing .....	13
— Fuse-bases .....	13
Dimension Drawings	
— OJON 1-1/1000 ja OJON 1-1 A 2500 .....	14
— OJON 1-1 A 2500/E3 ja OJON 1-1 A 4000/E2 .....	15
— OJON 1-10/630 E1 ja OJON 1-24/630/E .....	16
— OJON 3-1 A 1000 ja OJON 3-1/1600 .....	17
— OJON 3-1 A 2500 ja OJON 3-1 A 4000 .....	18
— OJON 3-10/630 ja OJON 3-10/1000 .....	19
— OJON 3-10/1600 ja OJON 3-12 A 2500 .....	20
— OJON OJON 3-12 A 4000 ja OJON 3-24 A 630 .....	21
— OJON 3-20/1000 ja OJON 3-20/1600 .....	22
— OJON 3-24 A 2500 ja OJON 3-24 A 4000 .....	23
— Terminals .....	24
— Disconnector earthing knives .....	25
— Disconnector control .....	26
— Auxiliary switches .....	27
— Installation and interlocking .....	28
— Extension bushing and support bearing .....	32
— Fuse-bases .....	33
— Manual operating device .....	35

# ABB OJON Indoor type Disconnectors

1...24 kV

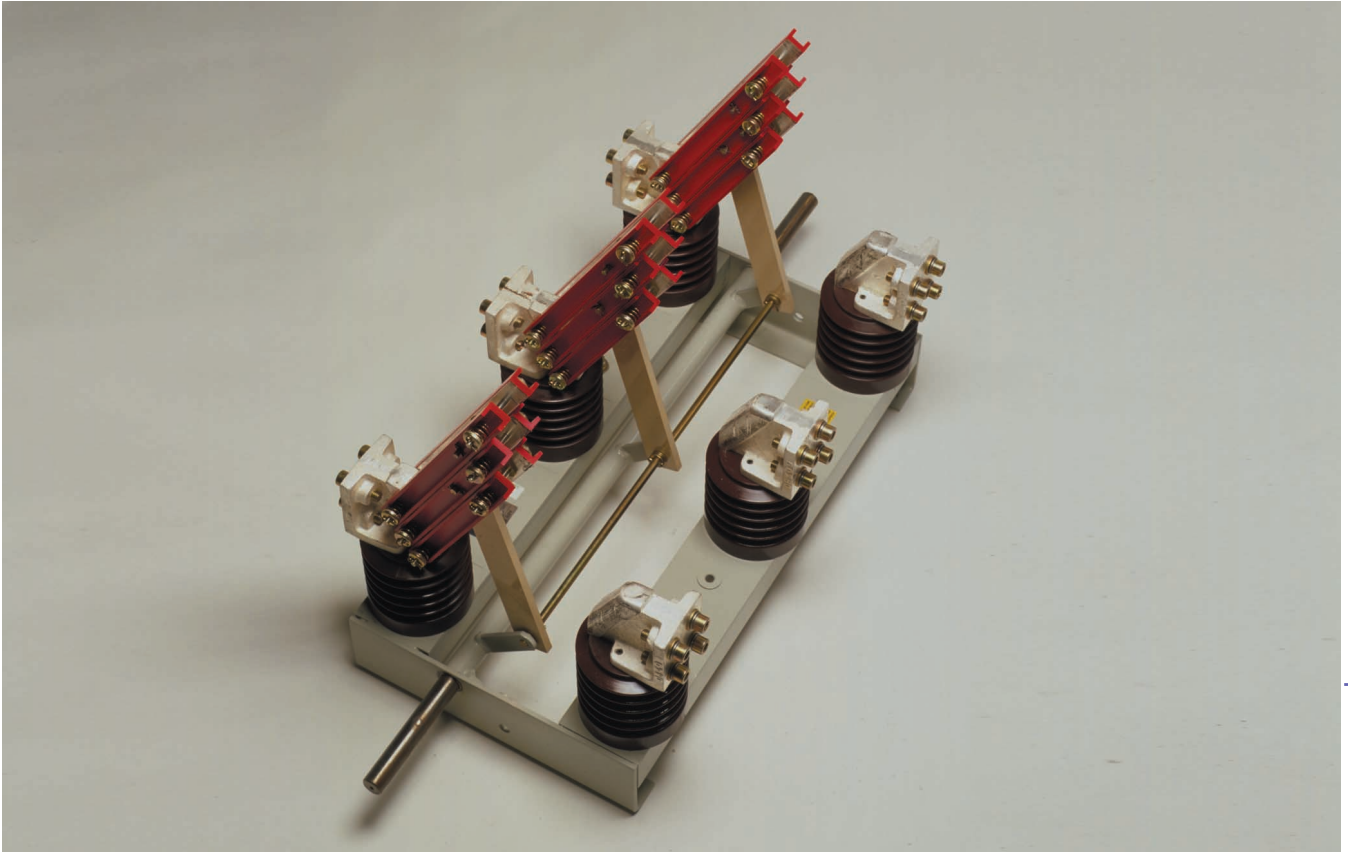

97-1038

Provided by Northeast Power Systems, Inc.  
www.nepsi.com

## General

Compact dimensions, direct current paths, double-knife construction and cast resin insulators are common to all OJON -type disconnectors.

The high short circuit strength of these disconnectors is a result of these features. Contact pressure is achieved by spiral springs which compress the knives.

Silver-plating prevents the contact area of the contact and knives from ageing, and keeps the temperature rise within the limits set by the standards. Owing to the double-knife construction, forces needed to operate the disconnectors remain moderate even at high rated currents.

The operating levers of the disconnectors can be mounted on a flat

base. Busbar joints OJON-ZWJ 5 and 6 may be used for disconnectors rated 2500 A and 4000 A. The frames and levers of the disconnectors are painted green, and the shaft terminals are treated with anti-rust varnish. The knives are painted red, which makes their position clearly visible and gives a pleasant look to the whole disconnector.

The contacts of the disconnectors are made of copper bar for 630 A and of cast copper for 1000...4000 A. Aluminium busbars can be connected, using jointing grease, to 630...1600 A, disconnectors, OJON-ZWJ 5 and 6 terminals and earthing switches.

## Special features of OJON disconnectors

- high short-circuit strength
- versatile control devices
- suitable for aluminium busbars
- compact dimensions
- silver-plated contacts
- cast resin insulators
- direct current paths
- double-knife construction
- red knives – position clearly indicated

# Indoor type Disconnectors

## Technical data and ordering information

### Standards and operating conditions

The disconnectors meet the requirements of IEC Publ. 129 (1984) and the Safety Regulations of the Finnish Electrical Inspectorate (Sähköturvallisuusmääräykset). In accordance with the standards, the ambient site temperature for indoor disconnectors, must be  $-25\text{ °C} \dots +35\text{ °C}$ , and the access of unusually high quantities of dust, smoke, caustic gasses and humidity to the site must be prevented.

Disconnectors OJON 3–1 A 1000, OJON 3–1/1600, OJON 3–1 A 2500 and OJON 3–1 A 4000 have been approved by the Register of Shipping of the U.S.S.R.

### Mounting

Normally the disconnectors are mounted in the upright position with the hinges at the bottom. Other positions are also possible provided that the operating or locking device ensure that the knives stay in the open or closed position. Wall mounting with the knives in a horizontal position must, however, be avoided, as the knives may bend down sideways from the bearings.

### Ordering information

1. Type and quantity.
2. Rated voltage  $U_r$ .  
See tables 1 and 2, pages 4 and 5.
3. Rated current  $I_r$ .
4. Rated peak withstand current  $I_p$ .  
 $I_p$  of the disconnector  $\geq$  network impulse short-circuit current  $I_s$ .  
The distance of the nearest post insulator is shown in table 2.
5. Rated short-time withstand current  $I_k$ .  
 $I_k$  of the disconnector  $\geq$  network  $I_{1s}$ .  $I_k$  is given in table 2 as 1 s value.  
Any other length of continuous short-circuit current  $I_{k2}$  of the network is reduced to 1 s value with the formula below.  
  
The formula is valid when the duration of  $t_{k2} > 1\text{ s}$ .  
 $I_k = I_{k2} \sqrt{t_{k2}} / \text{s}$ .  $t_k$  is the duration of  $I_{k2}$ .
6. Accessories: see table 3 on page 6.

### Operating voltage and voltage withstand levels

In accordance with IEC 694 (1980)

**Table 1**

Withstand voltages	Highest permissible operating voltage			
	1 kV	3.6 kV	12 kV	24 kV
Lighting impulse voltage 1.2/50 $\mu\text{s}$				
Across the isolating distance	23	46	85	145
Between phases and to earth	20	40	75	125
Power-frequency voltage 1 min				
Across the isolating distance	12	12	32	60
Between phases and to earth	10	10	28	50

# Indoor type disconnectors

## Technical data and ordering information

### Technical data

**Table 2**

Type	Rated voltage	Rated normal current	Rated short-time current	Rated peak withstand current	Distance of nearest post insulator from disconnector post insulator	Control torque	Isolating distance	Weight	Commercial code
OJON	kV	A	r.m.s. kA 1s	kA		Nm	mm	kg	
<b>3-1A1000</b>	1	1000/1250 <sup>2)</sup>	50	100	360 mm	40 ± 20	60	17	
<b>3-1/1600</b>	1	1600/2000 <sup>2)</sup>	80	120	400 mm	50 ± 20	70	43	
<b>3-1A2500</b>	1 <sup>1)</sup>	2500/2900 <sup>2)</sup>	90	150	350 mm	70 ± 30	70	49	
<b>3-1A4000</b>	1 <sup>1)</sup>	4000/4600 <sup>2)</sup>	90	150	350 mm	130 ± 40	65	65	
<b>3-10/630</b>	12	630	31,5	80	3 x a	40 ± 10	145	20	
<b>3-10/1000</b>	12	1000	40	100	3 x a	45 ± 15	165	35	
<b>3-10/1600</b>	12	1600	50	100	3 x a	60 ± 20	160	52	
<b>3-12A2500</b>	12	2500	60	150	3 x a	150 ± 30	140	71	
<b>3-12A4000</b>	12	4000	60	150	3 x a	160 ± 30	155	90	
<b>3-24A630</b>	24	630	20	50	3 x a	45 ± 15	265	25	
<b>3-20/1000</b>	24	1000	30	75	3 x a	60 ± 20	270	48	
<b>3-20/1600</b>	24	1600	40	100	3 x a	100 ± 20	265	65	
<b>3-24A2500</b>	24	2500	60	150	3 x a	180 ± 30	240	87	
<b>3-24A4000</b>	24	4000	60	150	3 x a	200 ± 40	260	109	

a = phase distance

(1 ) Highest permissible operating voltage 3.6 kV, see table 1 page 4.

(2 ) Higher value in acc. with IEC Publ. 408 (1972) when  $U_n \leq 660$  V.

Note: We can also deliver disconnectors with larger phase distances than detailed in the dimension drawings.

Single pole disconnector current values are the same as the corresponding three phase unit detailed in the table.

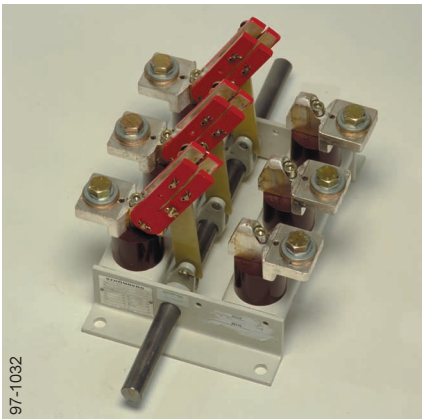

**OJON 3-1 A 1000**

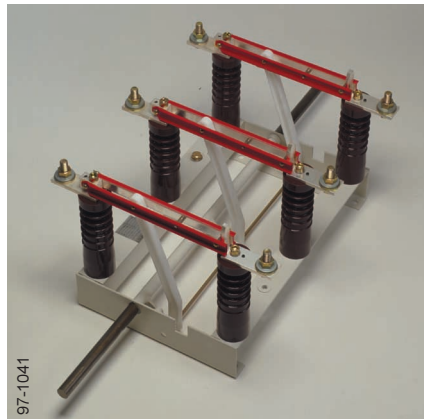

**OJON 3-24 A 630**

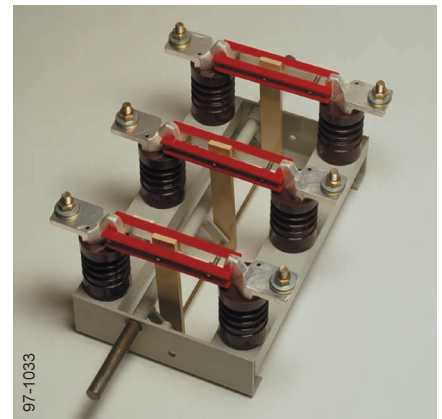

**OJON3-10/1000**

## Indoor type disconnectors Accessories

### Technical data and ordering information

**Table 3**

Accessories		Disconnector														Earthing switches		Page
		OJON 3-1 A 1000	OJON 3-1/1600	OJON 3-1 A 2500	OJON 3-1 A 4000	OJON 3-10/630	OJON 3-10/1000	OJON 3-10/1600	OJON 3-12 A 2500	OJON 3-12 A 4000	OJON 3-24 A 630	OJON 3-20/1000	OJON 3-20/1600	OJON 3-24 A 2500	OJON 3-24 A 4000	OJO-ZMA 10	OJO-ZMA 38	
Description	Type																	
Terminals	OJON-ZWJ 5 <sup>1)</sup>			o					o						o			24
	OJON-ZWJ 6 <sup>1)</sup>				o				o						o			24
Earthing switches	OJO-ZMA 10					o												7,25
	OJO-ZMA 38									o								7, 25
Operating arm	YASKA 25	o	o	o	o	o	o	o	o	o	o	o	o	o	o	o	o	7, 26
Insulated operating rod	NWA-ZS 5	o	o	o	o	o	o	o	o	o	o	o	o	o	o	o	o	7,26
	NWA-ZS 6	o	o	o	o													7, 26
Operating hook	NWA-ZH 6	o	o	o	o	o	o	o	o	o	o	o	o	o	o	o	o	7, 26
Manual operating mechanism	OJO-ZA 1 <sup>2)</sup>	o	o	o	o	o	o	o	o	o	o	o	o	o	o	o	o	7
	UEKO 2C3					o	o	o	o	o	o	o	o	o	o	o	o	8
Auxiliary switch	OLAN_AL 1	o	o	o	o	o	o	o	o	o	o	o	o	o	o	o	o	10
	OLAN + OLAN-ZT 4					o	o	o	o	o	o	o	o	o	o	o	o	11
Connecting levers + frame	OJO-ZAY 11 <sup>4)</sup>	o	o	o	o	o	o	o	o	o	o	o	o	o	o	o	o	35
Locking device	OJO-ZE 1 <sup>3)</sup>					o	o	o			o	o	o					29
	OJO-ZE 2 <sup>3)</sup>								o	o				o	o			29
Locking coil	OJO-ZLA 3 <sup>4)</sup>	o	o	o	o	o	o	o	o	o	o	o	o	o	o	o	o	12, 30
	OJO-ZLA 6 <sup>5)</sup>					o	o	o	o	o	o	o	o	o	o	o	o	12, 30
	UEKO-ZL 1 <sup>6)</sup>					o	o	o	o	o	o	o	o	o	o	o	o	12, 31
Extension shaft	BDAM 25 x L	o	o	o	o	o	o	o	o	o	o	o	o	o	o	o	o	13
Joint sleeve for extension shaft	OJE-ZAA 25	o	o	o	o	o	o	o	o	o	o	o	o	o	o	o	o	13, 32
Support bearing	OJO-ZU 3					o	o	o	o	o	o	o	o	o	o	o	o	13, 32

- 1) Also applicable for aluminium busbars.
- 2) Depending on the mounting of the operating mechanism, the operating lever may turn below the mounting level.
- 3) Prevents the horizontally mounted disconnector from closing under its own weight.
- 4) For manual operating mechanism OJO-ZA 1.
- 5) Mounted on the side plate of the disconnector.
- 6) For use with manual operating mechanism UEKO 2C3.

# Accessories

## Earthing knives, operating arms and manual operating devices

### Technical data and ordering information



98-1060  
**Disconnector fitted with earthing knives**



93-1065  
**Motor operating mechanism UEMC 40\_**

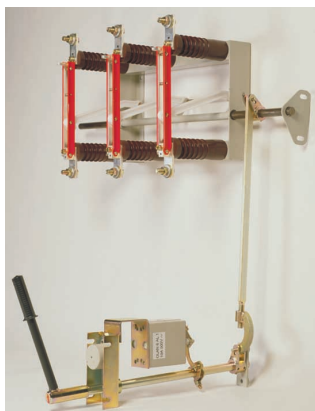

98-1042  
**Manual operating mechanism OJO-ZA 1 with accessories**



98-1039  
**Manual operating mechanism and angle link**

## Earthing Knives

As shown in table 3 (page 6) the 630 A OJON\_ disconnectors can be supplied with either an upper or lower earthing knives. Earthing knives have the same short-circuit strength as the corresponding disconnectors.

The main switch and earthing knives are interlocked with a locking device so that they cannot be closed simultaneously. The locking device is normally on the left side of the disconnectors. A locking device prevents the earthing knife from opening and closing under its own weight.

## Disconnector control

The following can be used as an operating mechanism for the disconnectors:

- operating rod NWA-ZS 5 (> 1 kV) or NWA-ZS 6 ( $\leq$  1 kV) and hook end NWA-ZH 6 and arm YASKA 25
- manual operating mechanism OJO-ZA 1 or UEKO 2C3
- motor-operated control mechanism UEMC 40\_. Refer to catalogue 34 UEMC 36\_ and 34 UEMC 44\_.

## Motor Operating device UEMC 40\_

The type and construction of motor operating device depends on the location and accessories required. The device can be fitted to the disconnector shaft or the front of the cubicle. When mounting on the shaft, check that there is enough space between the disconnector shaft and mounting surface. When the motor operating device is fitted on the front of the cubicle, the drive is transferred using a lever system. Local electrical control (Pushbuttons) of the operating device is available.

Manual operation is also possible by using an operating rod or control handle when a motor operating device is fitted.

## Operating arm

The simplest control mechanism is an operating arm and an operating rod. Opening of the disconnector can be prevented with locking coil OJO-ZLA 6.

## Manual operating mechanism, alternative A, OJO-ZA 1

The manual operating mechanism OJO-ZA 1 for mounting on the front wall of the cubicle, interlocks the disconnector in the extreme positions with the help of a stall lever. A suspended pin ensures retention in these positions. The end that comes through the front panel of the cubicle is covered with a protective cover that can be locked with a padlock. The manual operating mechanism can be supplied both with locking coil OKO-ZLA 3 and auxiliary switch OLAN-AL 1. When there is no auxiliary voltage, the interlock (of the locking coil) can be opened manually. In accordance with the standards, the closing movement of the disconnector is from down-position to up-position.

**Accessories**  
**Earthing knives, operating arms and manual operating devices**  
**Technical data and ordering information**



**Manual operating mechanism, alternative B, UEKO 2C3**

This manual operating mechanism comprises of a beveled gear on the end of a shaft from the disconnecter, a joint fitted with a position indicator on the front panel and a control tube joining the two parts. Due to the joint, the control tube can be moved through an angle of  $\pm 40$  degrees from the vertical position. The tube is to be cut to a suitable length when installing. The indicator locks the disconnecter in the extreme positions. The operating mechanism may also be locking with a locking coil UEKO-ZL 1 and padlock. By turning the angle of the beveled gears the operating direction of the disconnecter can be adjusted to always be the same.

**Ordering information**

**Alternative A**

1. Quantity and type designation.
2. Types of shaft and intermediate rods.  
(Dimensions for A and B given in the table below and in drawing on page 35).
3. Type of support bearing.
4. Accessories (e.g operating handle) see page 6.

**Alternative B**

1. Quantity and type designation.
2. Tube length 2500 mm if the standard length of 1500 mm is too short.
3. Additional accessories on page 6.

**Delivery lengths**

<b>Dimension A</b>	<p><b>Alternatives:</b></p> <p>OJO-ZAA 1 x 1200 shaft , A max = 1200 mm            1 x 1800 , " = 1800 mm</p>
<b>Dimension B</b>	<p><b>Alternatives:</b></p> <p>OJO-ZAW 1 x 150 flat intermediate bar , B max = 230 mm            1 x 700 , " = 780 mm</p> <p>OJO-ZAW 2 x 1300 flat intermediate bar , " = 1380 mm            2 x 1800 , " = 1880 mm            2 x 2800 , " = 2880 mm</p>

**NOTE!** If dimensions A and B differ from the standard dimensions the next standard size will be cut to a suitable length when mounting. Fine adjustment of the intermediate bars is between  $\pm 20$  mm.



## Accessories

### Support bearing

Technical data and ordering information

### Support bearing

Description	Type	Application	Page
Support bearing	OJO-ZU3	OJON 3-10 ... 24_	32

### To be ordered separately

Description	Type	Application, OJO-ZA1 (UEKO 2C3)	Page
Auxiliary switch	OLAN 6 AL 1	6 change-over contacts	27
	OLAN 9 AL 1	9 change-over contacts	35
Power reduction levers and frame	OJO-ZAY 11	For auxiliary switch	35
Locking coil	OJO-ZLA 3 UEKO-ZL 1	Locks the manual operating mechanism (UEKO 2C3) into the extreme positions	30
Angle link	YAEWK 3		26
Tubular intermediate bar	OJ-ZDU 7 x 1500 OJ-ZDU 7 x 2500	Cut off to a suitable length when mounting. C can be min. 550 mm.	35
Operating handle	OJO-ZAK 1 OJO-ZAK 2 UEKO-ZK 1	OJO ZA 1 OJO-ZA 1 (UEKO 2C3)	26

## Auxiliary switches

### Technical data and ordering information

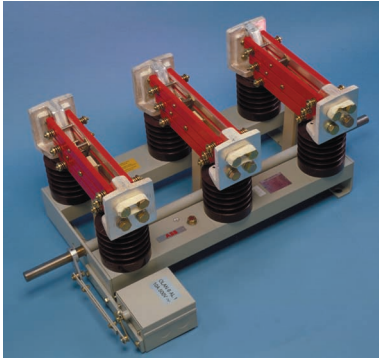

97-1029

**OLAN 6 AL 1, OLAN-ZT 4  
and YAWAS 6 fitted to  
OJON 3-12 A 4000  
disconnecter**

## Auxiliary switches

Auxiliary switch OLAN-AL 1 can be fixed to the cubicle wall, in connection with manual operating mechanism or to the frame of the disconnector. The movement is transmitted from the shaft of the disconnector or manual mechanism to the switch with levers and intermediate bars. Switches are available with 6 or 9 change-over contacts. The contacts are silver-plated and are double breaking. Protection class is IP20.

### Technical details of auxiliary switches

Insulation class	500 V
Continuous load current	16 A
Breaking capacity over 5000 breaks when L/R < 40 ms	
24 V–	16 A
60 V–	10 A
110 V–	5 A
220 V–	2 A
Mechanical life 10 000 operations	

### Position indication

The auxiliary switch has a position indicator which can be used when adjusting the movement transmission levers. The contact diagram shows the operation of the contacts as the function of the turning angle of the control lever

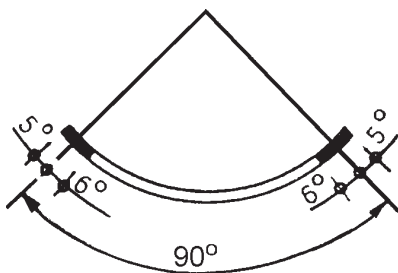

**Contact diagram**

### To be ordered separately

- Terminals and cable glands MRRNL 16 tai 21
- Universal tube terminal MRPA 16 tai 21
- Pica sensor RPLA 16 tai 23
- For additional parts see page 11

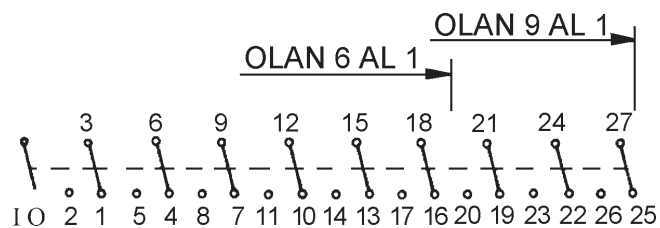

**Connection diagram**

The largest conductor size that can be connected is 4 square mm.

**Auxiliary switches**  
**Additional parts**  
 Technical data and ordering information

**Additional Parts**

Mounting of auxiliary switch	Parts		Note	Page
	Description	Type		
To manual operating mechanism OJO-ZA 1	Transmission levers with frame	OJO-ZAY 11		35
For fixing on OJON 3-10...24 kV disconnecter	Adjustable lever	YAWAS 6	Models of installation p.20	29
	Support and intermediate link	OLAN-ZT 4	1. 630...4000 A 2. 630...4000 A 3. 630...1000 A on the left or the right side. Choise of mode of installation as effect by the placing of the earthing switches, locking coil and chock absorber. OJON 3- <sup>10</sup> + OLAN 9- only mode <sup>12</sup> 3 and 4 of installation.	28
For separate mounting	Intermediate bar	OJ-ZDU 3x2000 OJ-ZDU 4x2000	The bar is to be cut to a suitable length when mounting	28
	Adjustable lever	YAWAS 6	For shaft diam. 25	

# Interlocking

## Technical data and ordering information

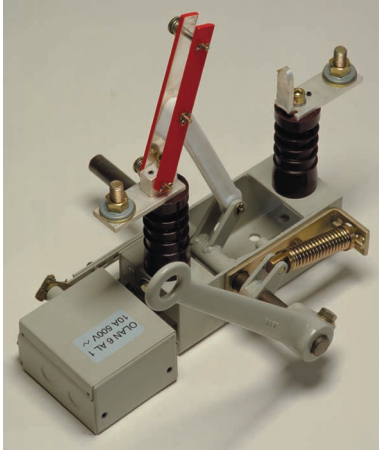

97-1036

**Locking device, arm and auxiliary contacts fitted on OJON 1-10/630/E1 disconnecter.**



99-1013

**Locking coil OJO-ZLA 3**

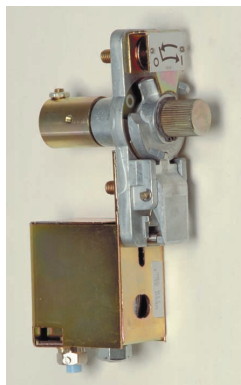

97-1050

**Locking coil UEKO-ZL 1**

### Interlocking

The use of locking devices in connection with different disconnectors is detailed in table 3, page 6.

#### A. Disconnector interlocking when subject to gravity or short-circuit and other disturbances

When operating arm controlled, the disconnectors are interlocked with locking device OJO-ZE\_ or locking coil OKO-ZLA 6. When the disconnector is mounted in a horizontal plane, locking device OJO-ZE\_ must always be used to prevent the knives from closing under their own weight. Manual operating mechanism OJO-ZA 1 locks the disconnector in the closed and the open position with no additional equipment.

#### B. Disconnector interlocking to prevent unintentional operation

When operating arm controlled, locking coil OJO-ZLA 6, which is fixed to the frame of the disconnector is used. Manual operating mechanism OJO-ZA 1 can be locked with a padlock or locking coil OJO-ZLA 3. Manual operating mechanism type UEKO 2C3 can be locked with a padlock or locking coil UEKO-ZL 1.

### Locking coils

The auxiliary control voltage of locking coils (OJO-ZLA 3 and 6) is either DC or full-wave rectified alternating current. In the absence of voltage, the interlock can be opened by pulling the armature with the operating rod or by hand. Locking coil OJO-ZLA 3 is used with the operating mechanism while locking coil used OJO-ZLA 6 is fixed to the left or right side of the disconnector. Locking coil UEKO-ZL1 is to be fitted to the manual operating mechanism UEKO 2C3 position indicating device on the inside of the cubicle.

### Voltage of interlockup coil

Voltage	OJO-ZLA 3, 6	UEKO ZL 1	Coil consumption and time constant
24 VDC	X	X	OJO-ZLA3 12 W 40 ms
30 VDC	X		
48 VDC	X	X	
60 VDC	X	X	
110 VDC	X	X	
125 VDC	X	X	
220 VDC	X	X	1) Rectifier included
230 VAC	X 1)	X	

### Ordering information

1. Type and quantity
2. Coil voltage
3. Is locking coil OJO-ZLA 6 on the right or the left side of the disconnector.

## Interlocking

### Technical data and ordering information



**Extending the shaft**

### Extension shaft and support bearing

When needed, the shaft of the disconnector can be extended with extension shaft BDAM 25 x L. Extension sleeve OJE-ZAA 25 with its spring bolt pin and 1 or 2 support bearings OJO-ZU 3 are then needed.

#### To be ordered separately

Extension shaft dim. 25 x L  
Dimension L must be given when ordering.  
Weight: 3.85 kg per meter

### Fuse-bases

The frame of the fuse-bases is made of steel plate and the insulators of cast resin. Fuse-links in accordance with DIN 43625 are suitable for the bases.

The fuse bases can be fitted with fuse blown auxiliary contacts. The auxiliary contacts are 1 NC rated at 10A.

#### To be ordered separately

Fuse cartridges -EBD CEF\_. Refer to brochure CEF\_CMF 1.  
Fuse changing handle O-ZHPA 5



**Fuse bases  
12 and 24 kV**

**Indoor type disconnecter**  
**OJON 1-1**  
 Dimension drawings

**OJON 1-1/1000**

**1 kV 1000 A**

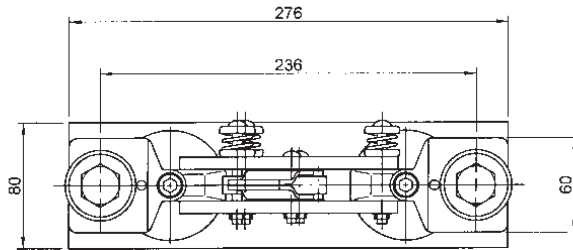
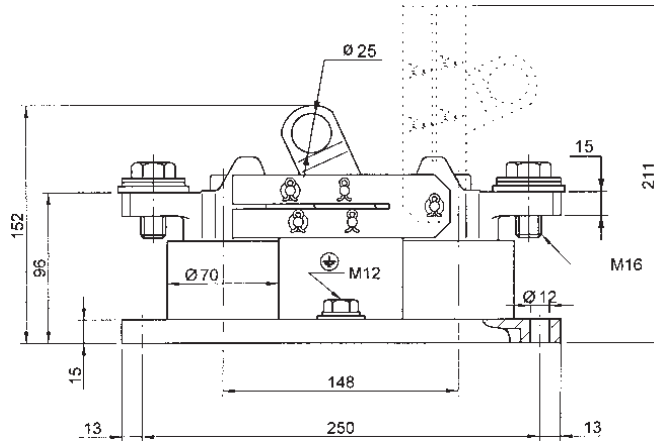

OJON12

**OJON 1-1 A 2500**

**1 kV 2500 A**

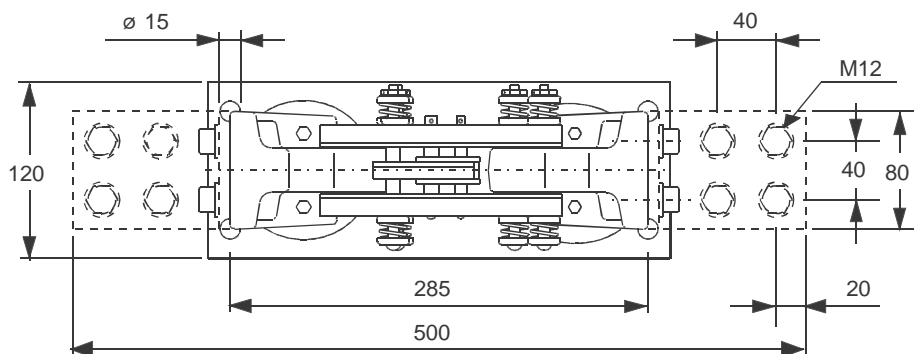
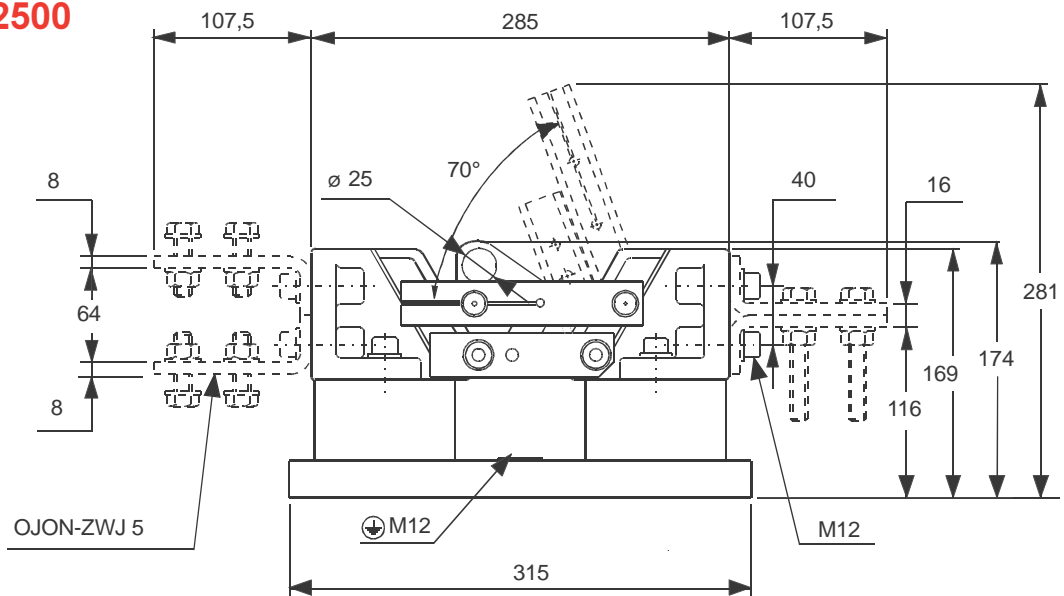

OJON13

**Indoor type disconnectors**  
**OJON 1-1**  
 Dimension drawings

**OJON 1-1 A 2500/E3**

**1 kV 2500 A**

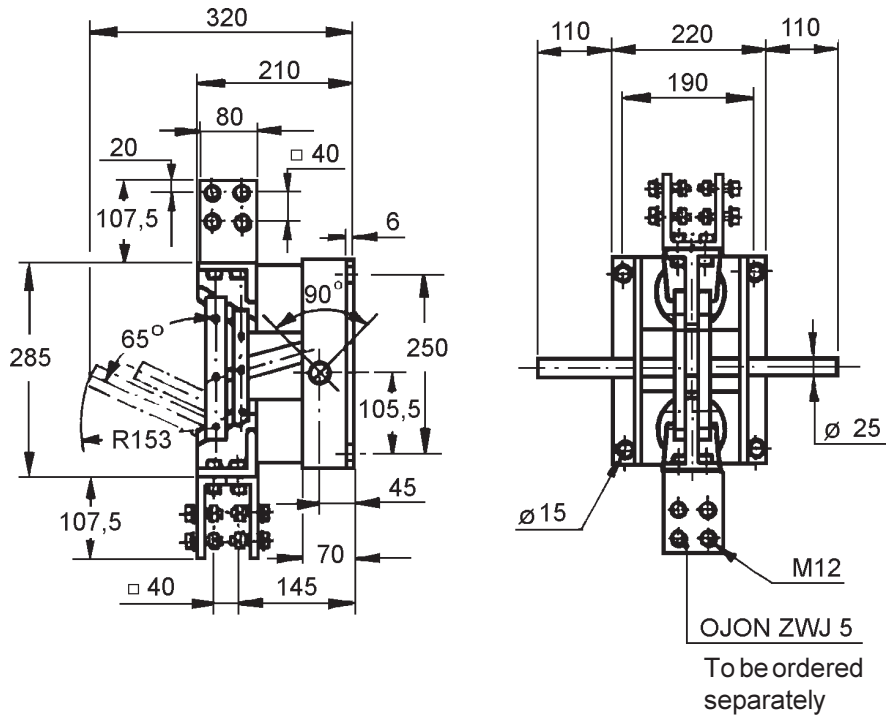

**OJON 1-1 A 4000/E2**

**1 kV 4000 A**

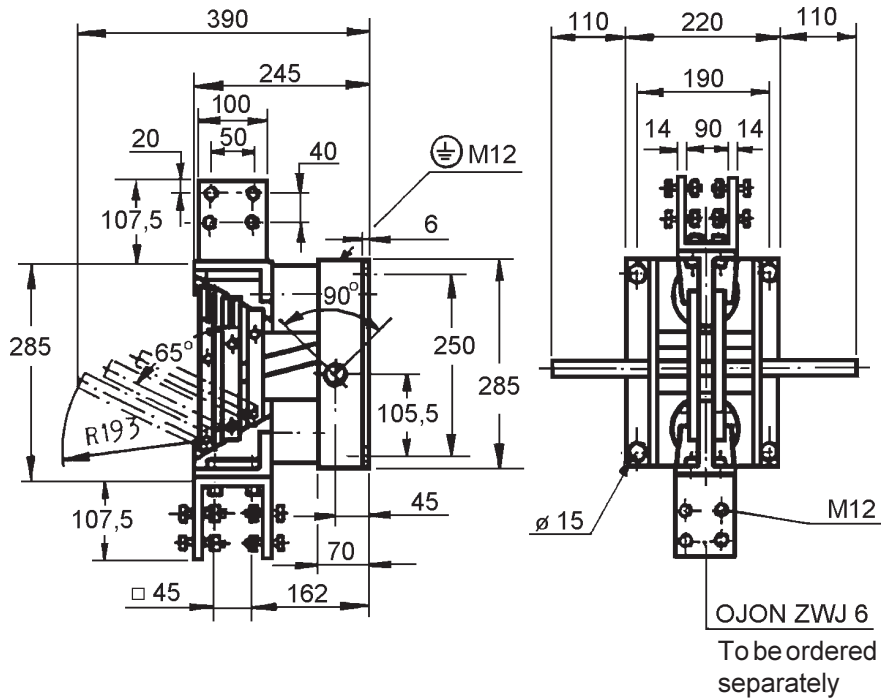

**Indoor type disconnectors**  
**OJON 1-1**  
 Dimension drawings

**OJON 1-10/630 E1**

**12 kV 630 A**

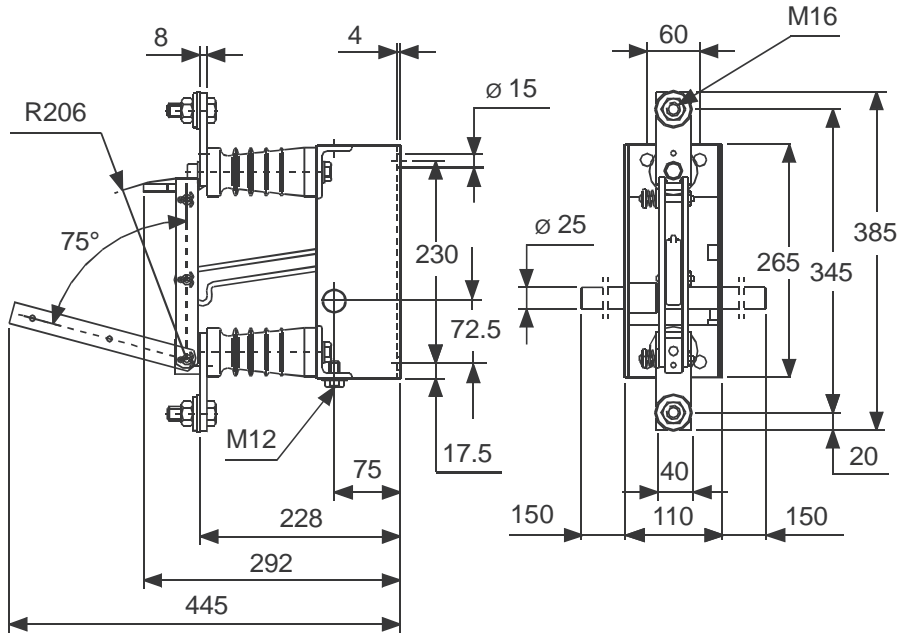

OJON18

**OJON 1-24/630/E**

**24 kV 630 A**

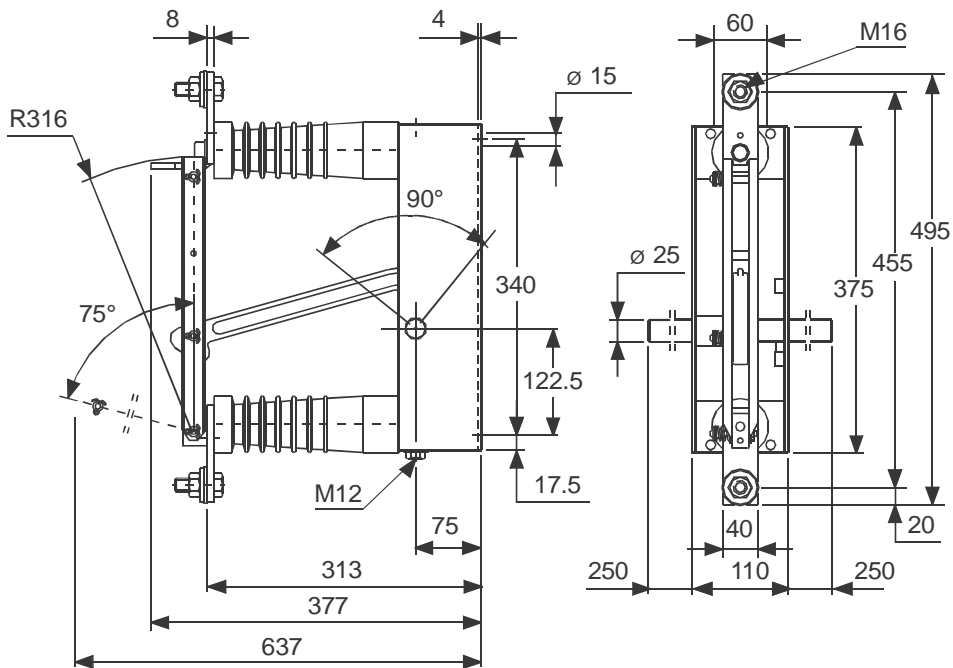

OJON11



**Indoor type disconnectors**  
**OJON 3-1**  
 Dimension drawings

**OJON 3-1A 1000**

**1 kV 1000 A**

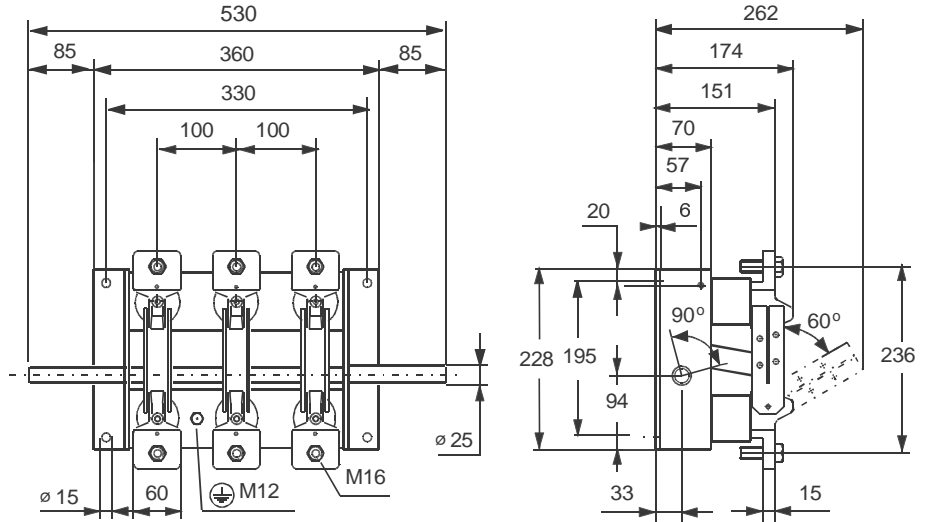

OJON 38

**OJON 3-1/1600**

**1 kV 1600 A**

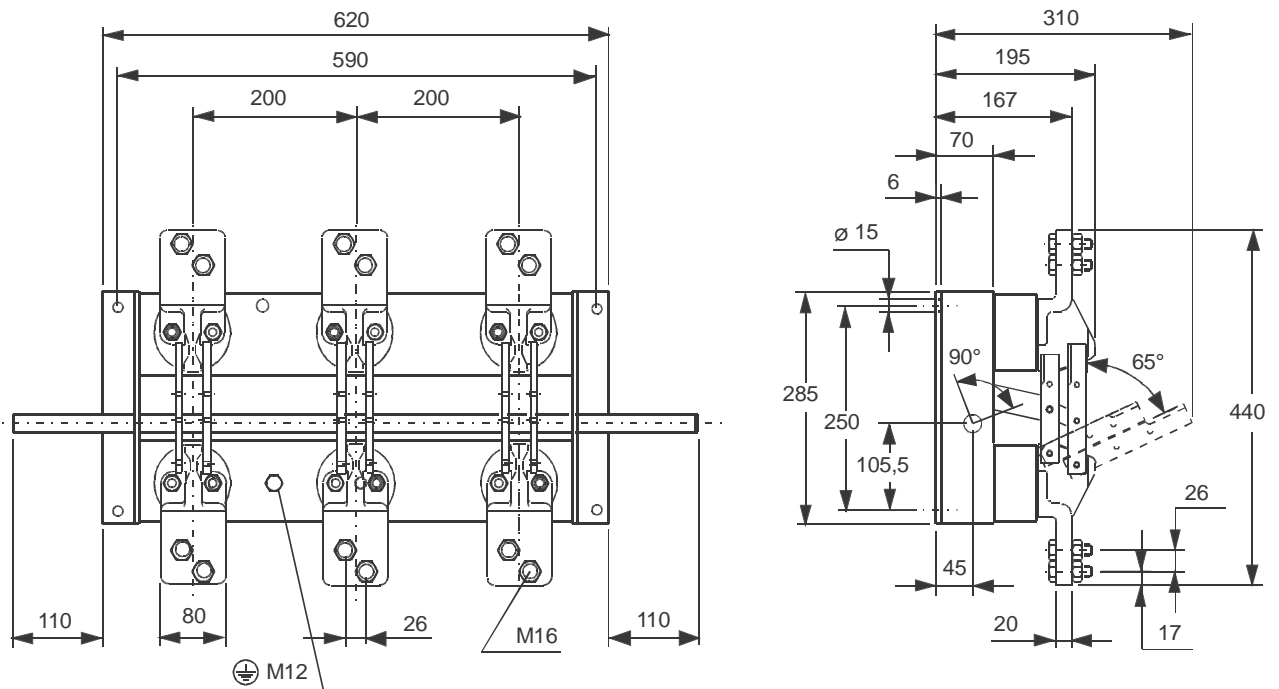

OJON 39

**Load type disconnectors**  
**OJON 3-1**  
 Dimension drawings

**OJON 3-1 A 2500**

**1 kV 2500 A**

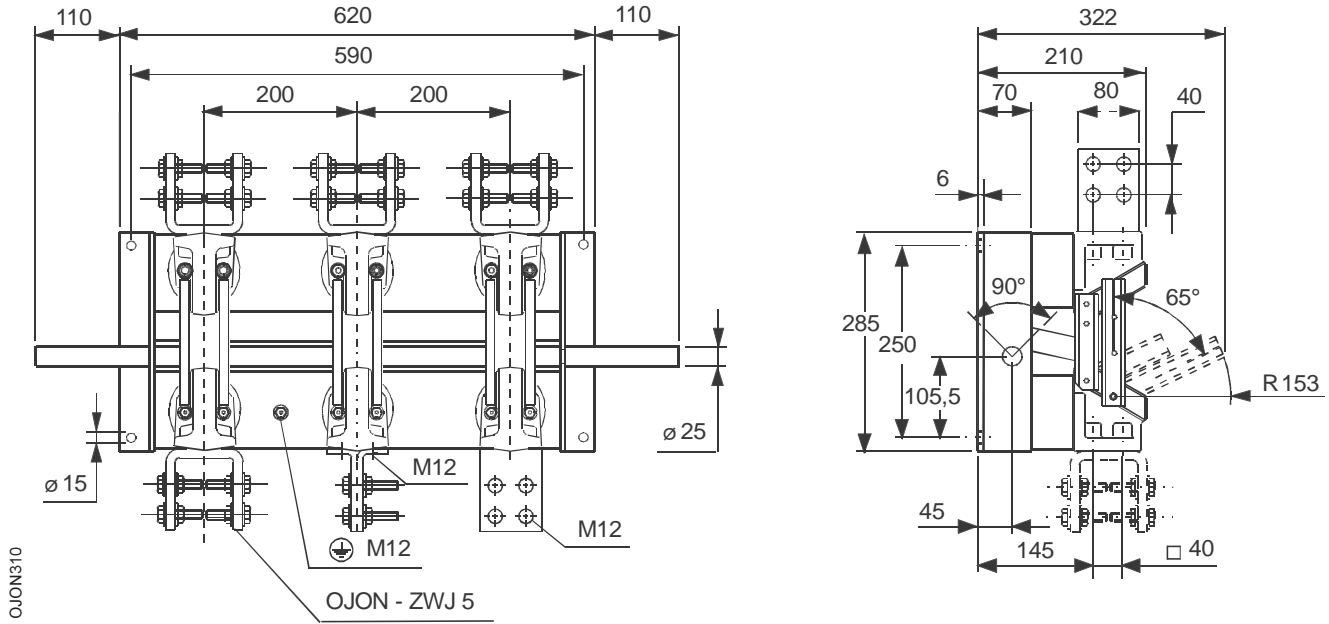

**OJON 3-1 A 4000**

**1 kV 4000 A**

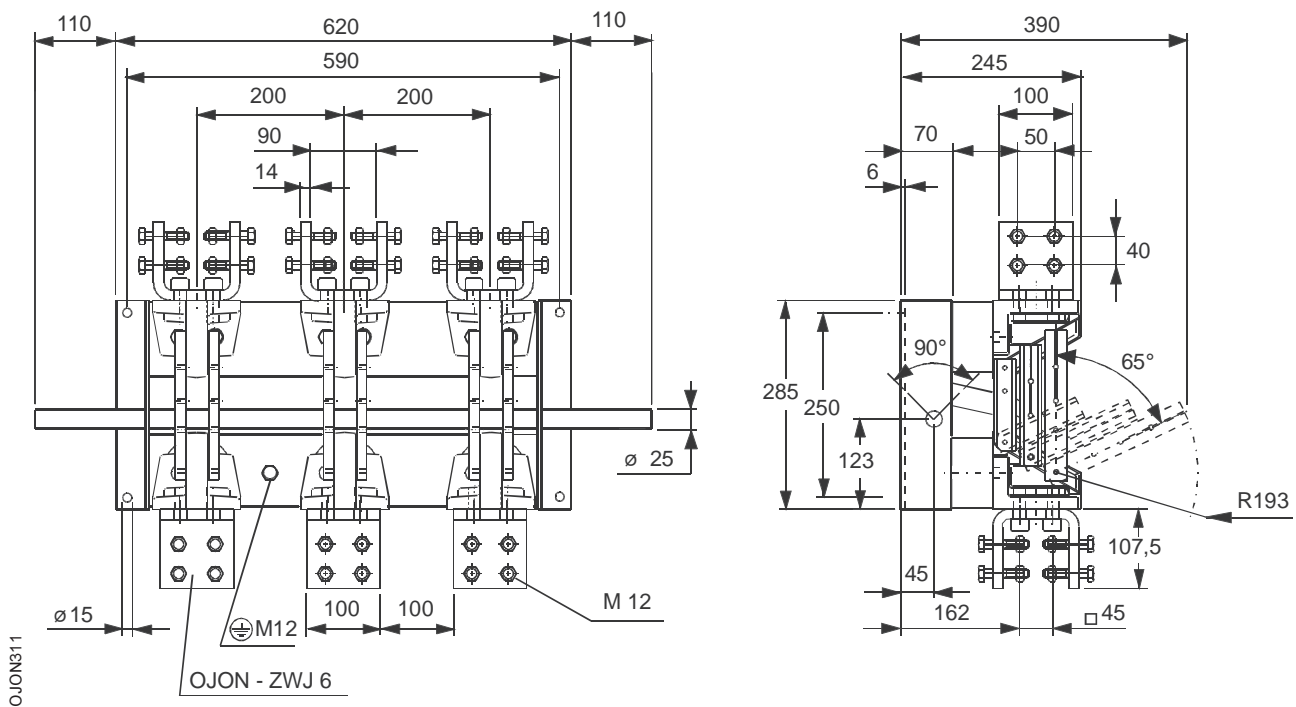

**Indoor type disconnectors**  
**OJON 3-10**  
 Dimension drawings

**OJON 3-10/630**

**12 kV 630 A**

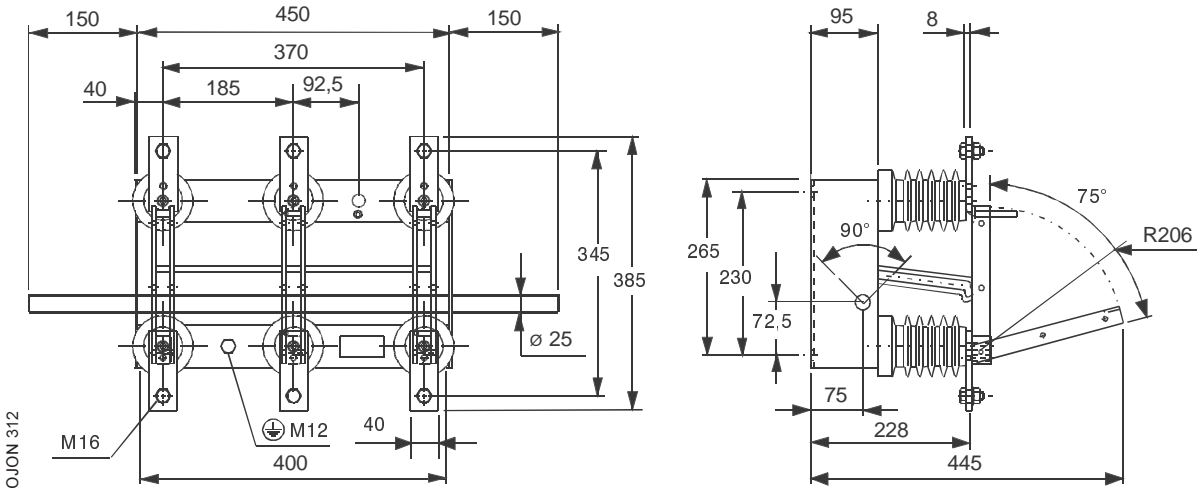

**OJON 3-10/1000**

**12 kV 1000 A**

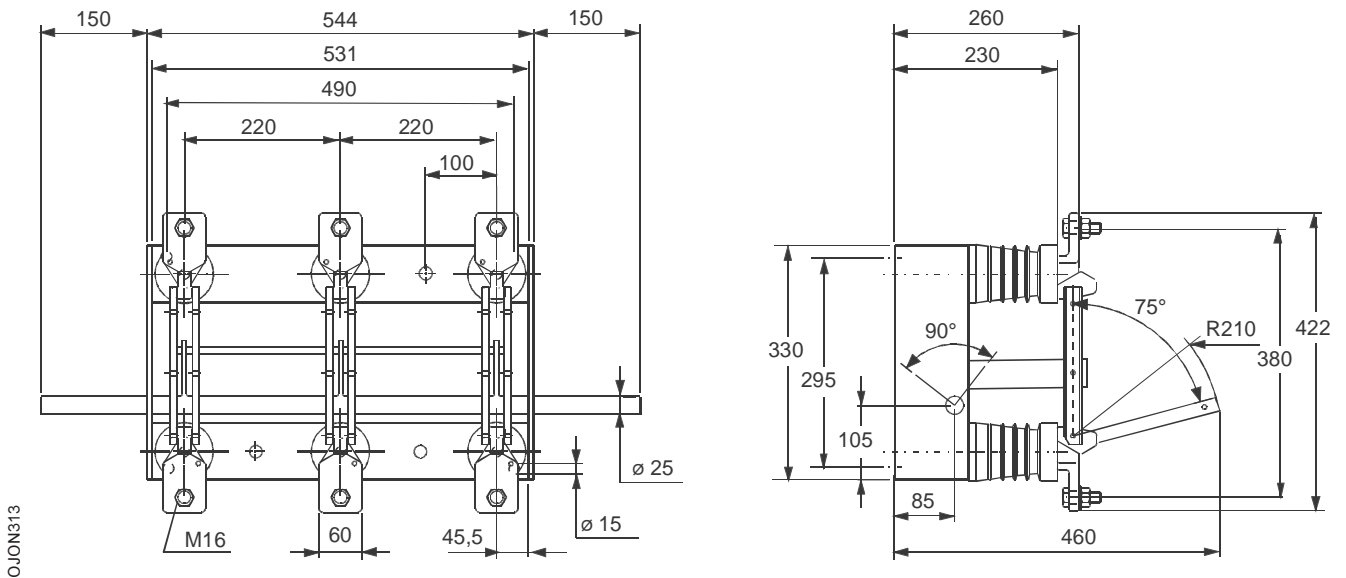

Provided by Northeast Power Systems, Inc.  
[www.nepsi.com](http://www.nepsi.com)

**Indoor type disconnectors**  
**OJON 3-10**  
 Dimension drawings

**OJON 3-10/1600**

**12 kV 1600 A**

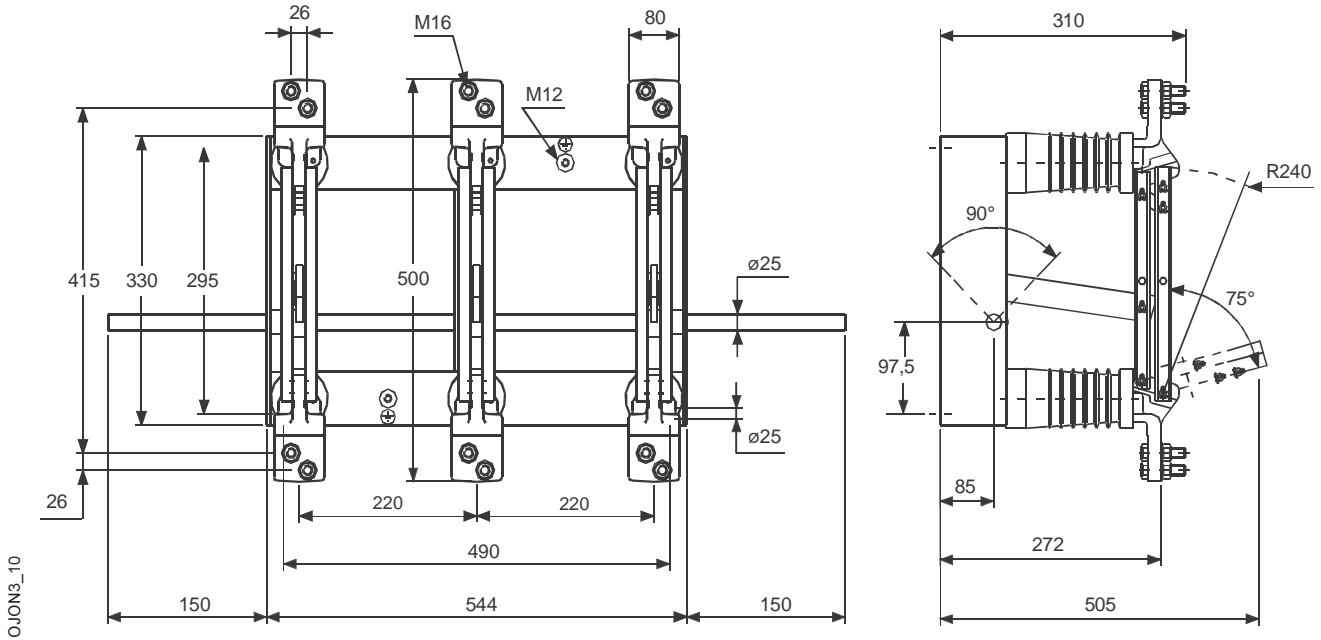

OJON3\_10

**OJON 3-12 A 2500**

**12 kV 2500 A**

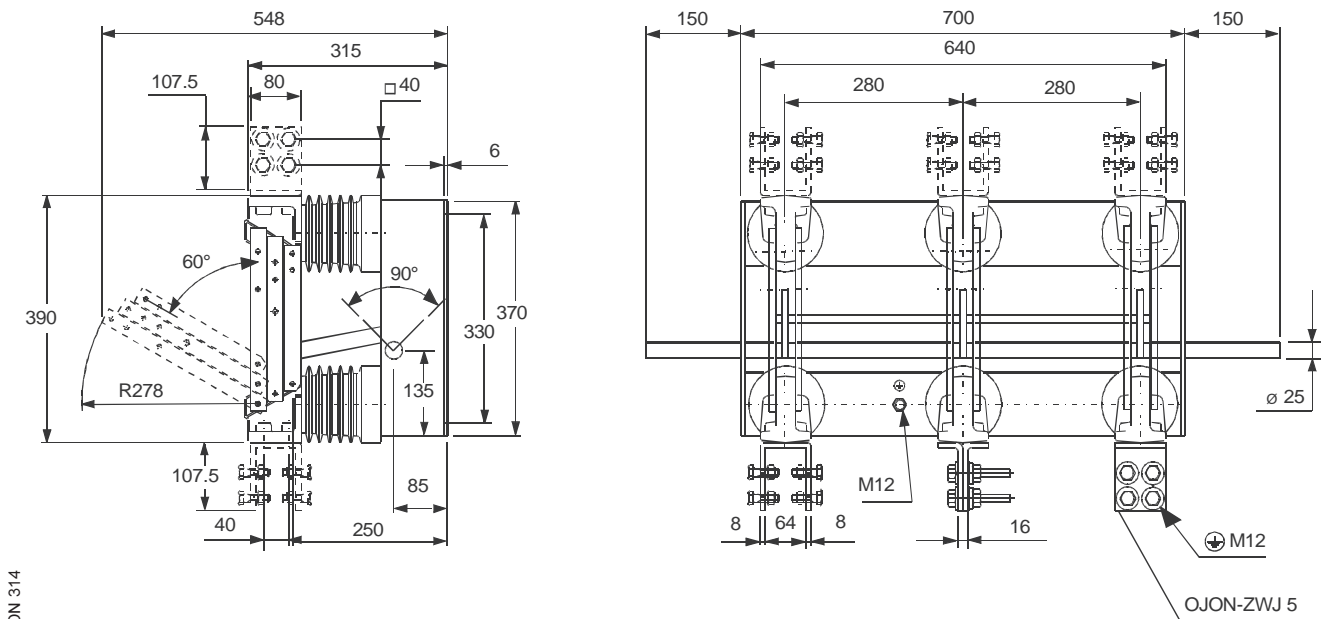

OJON 314

**Indoor type disconnectors**  
**OJON 3-12**  
 Dimension drawings

**OJON 3-12 A 4000**

**12 kV 4000 A**

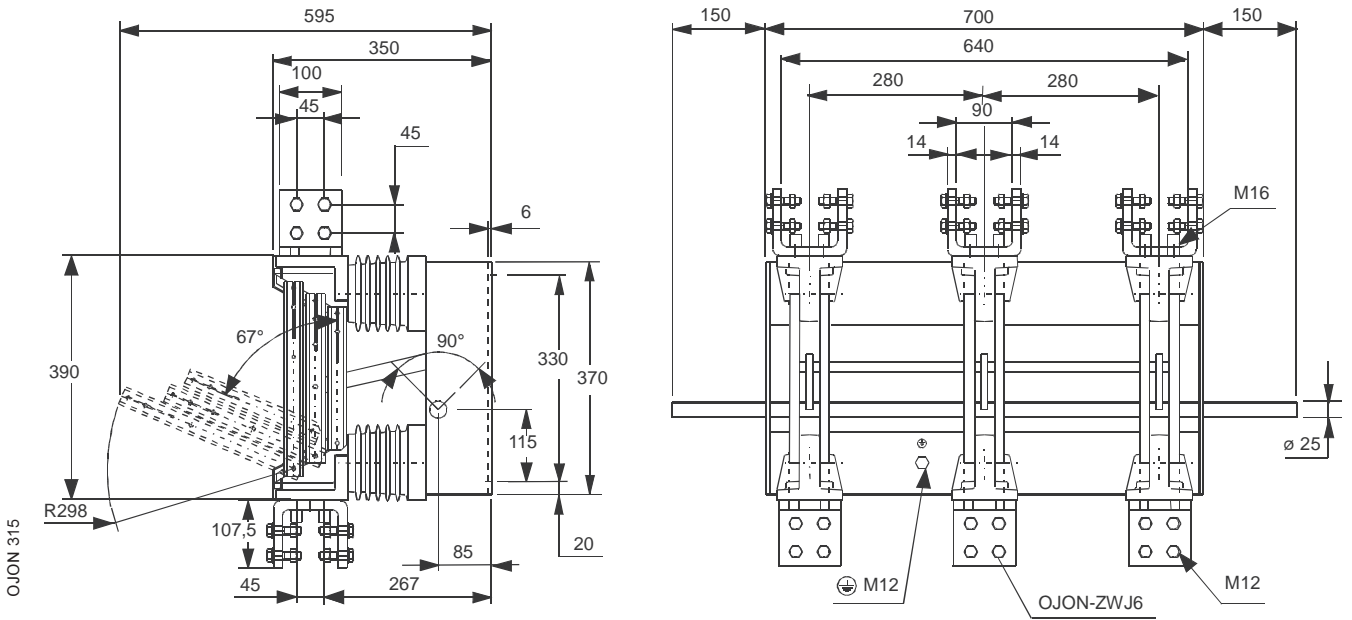

**OJON 3-24 A 630**

**24 kV 630 A**

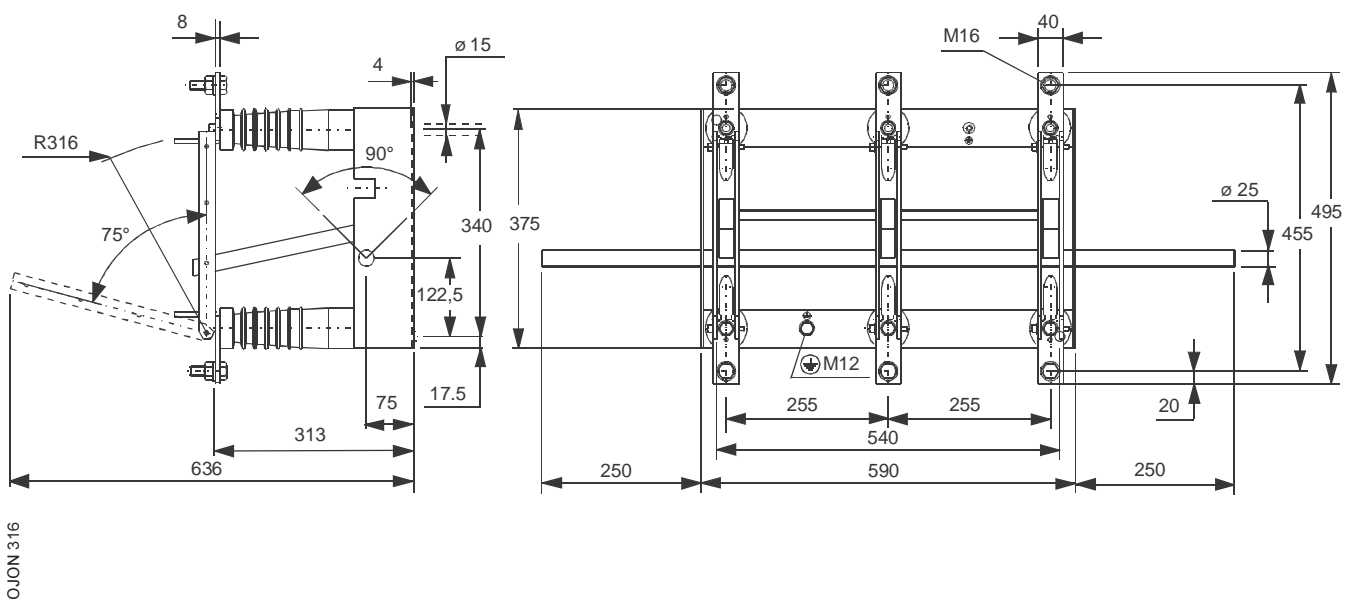

Provided by Northeast Power Systems, Inc.  
 www.nepsi.com

**Indoor type disconnectors**  
**OJON 3-20**  
 Dimension drawings

**OJON 3-20/1000**

**24 kV 1000 A**

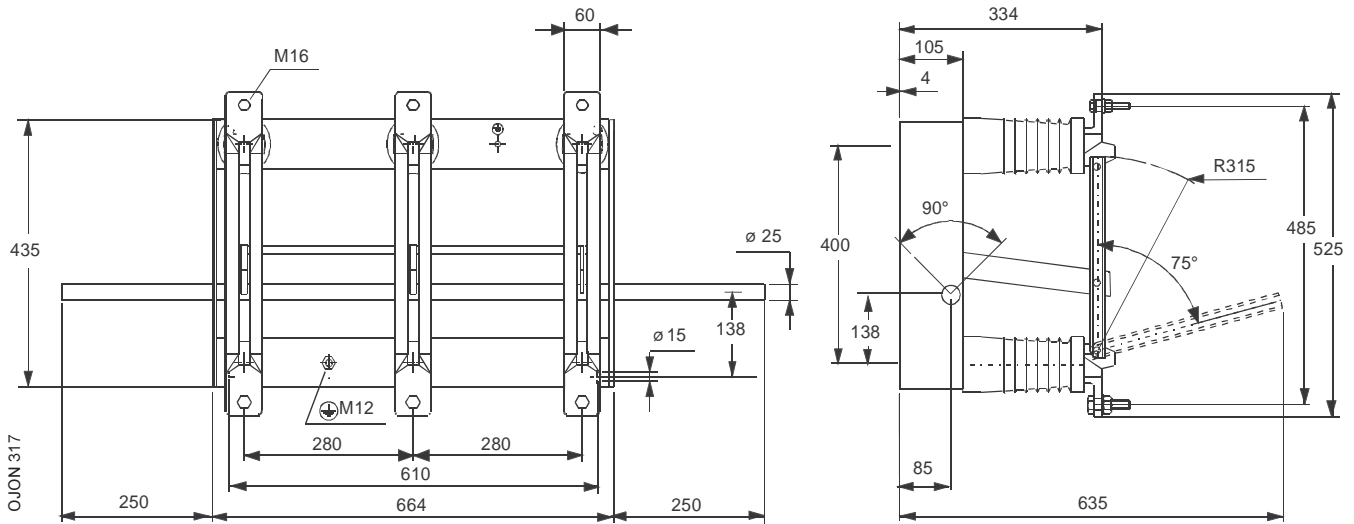

**OJON 3-20/1600**

**24 kV 1600 A**

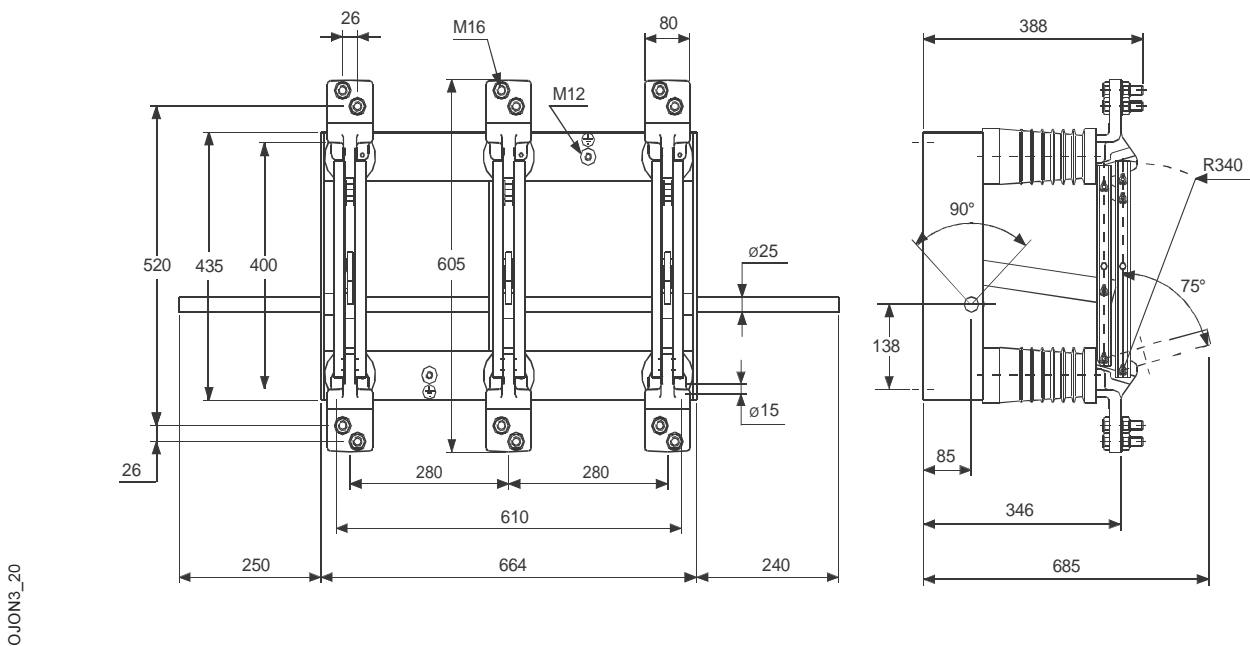

# Indoor type disconnectors

## OJON 3-24

### Dimension drawings

#### OJON 3-24 A 2500

24 kV 2500 A

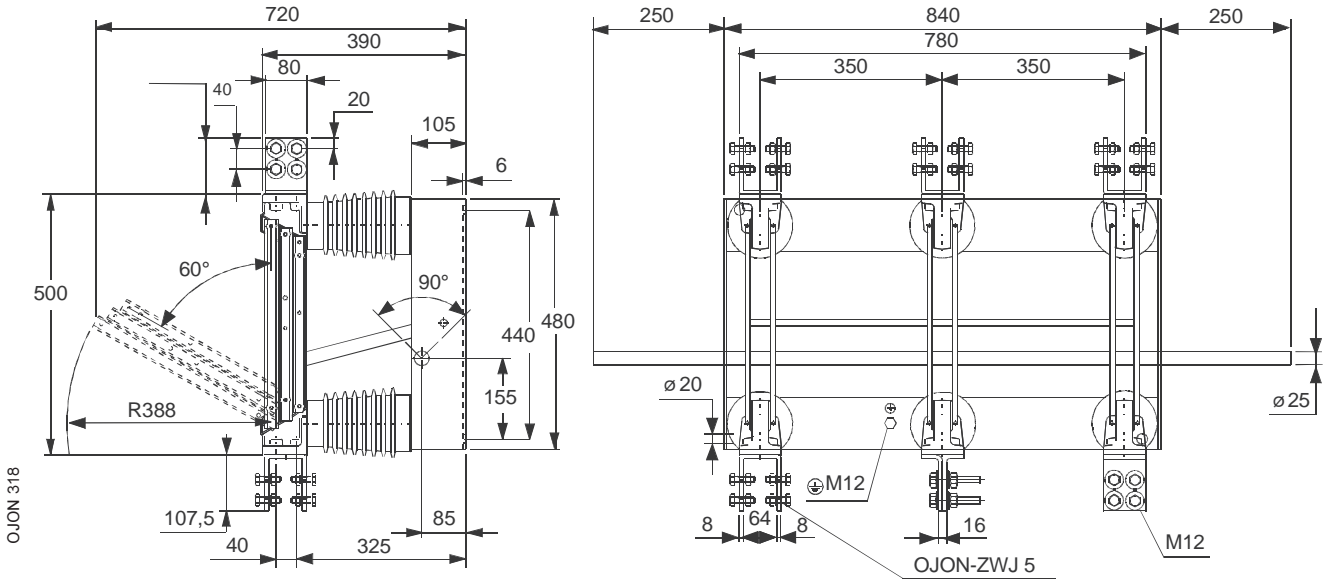

#### OJON 3-24 A 4000

24 kV 4000 A

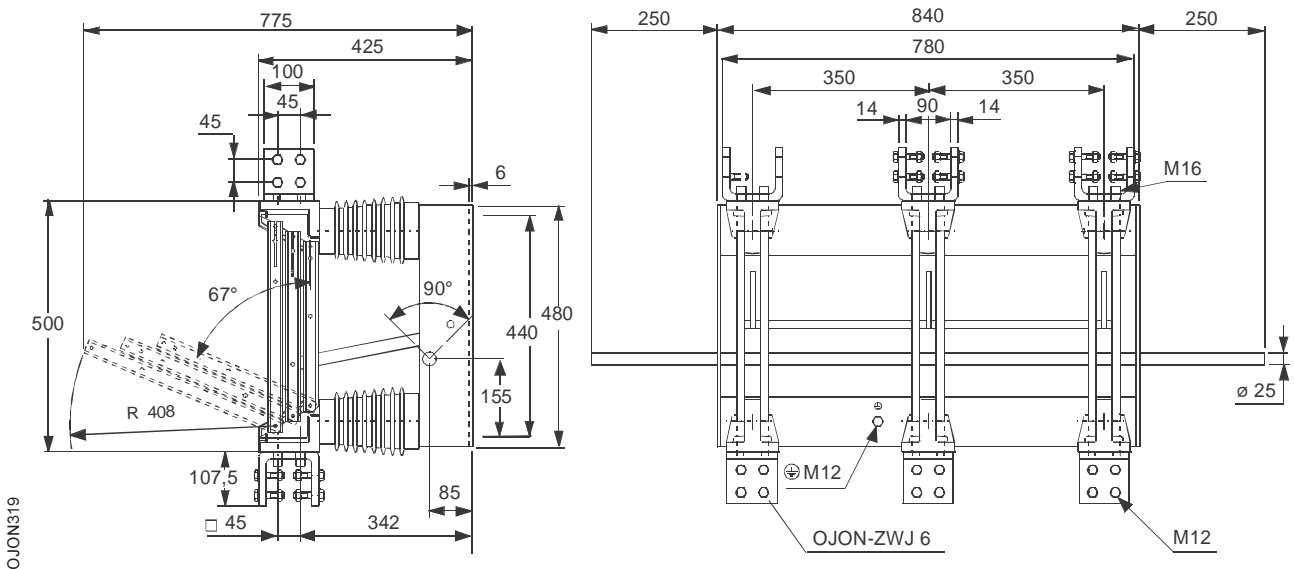

Provided by Northeast Power Systems, Inc.  
[www.nepsi.com](http://www.nepsi.com)

# Terminals

## Dimension drawings

### 2500 A terminal

#### OJON-ZWJ 5

To be ordered as required for 2500 A disconnectors.

Silver plated electrolytic copper.

Weight: 2.1 kg

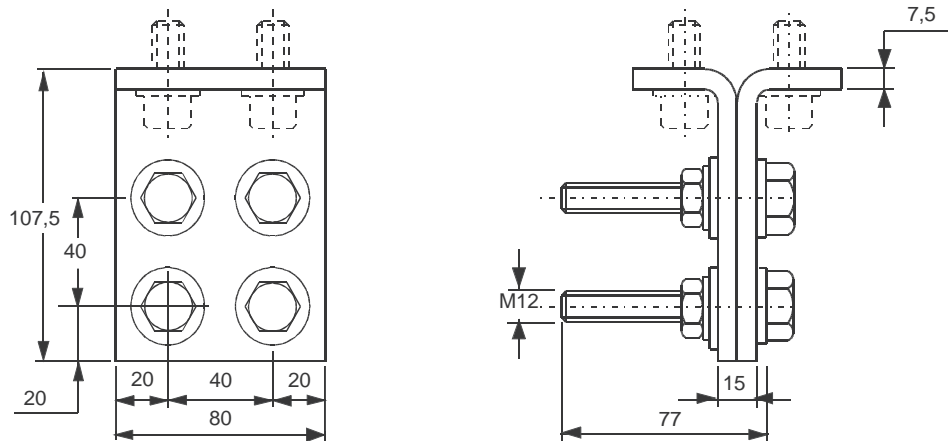

OJONZWI1

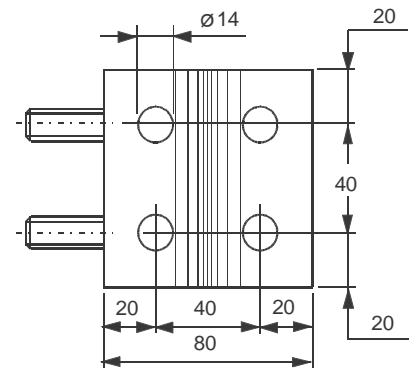

### 4000 A terminal

#### OJON-ZWJ 6

To be ordered as required for 4000 A disconnectors.

Silver plated electrolytic copper.

Weight: 4.45 kg

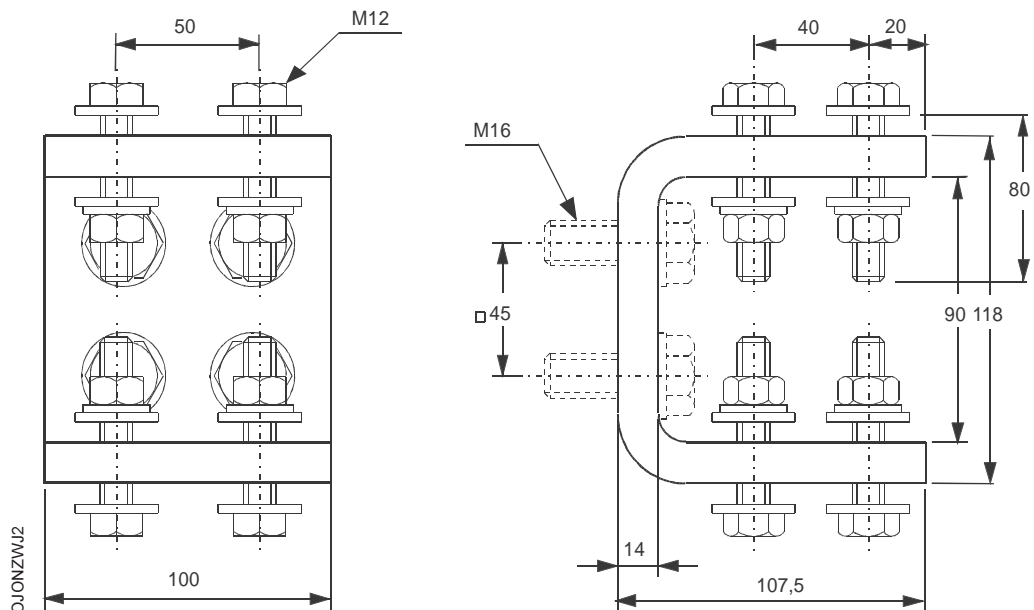

OJONZWJ2



# Earthing knives

## Dimension drawing

### Disconnecter earthing knives

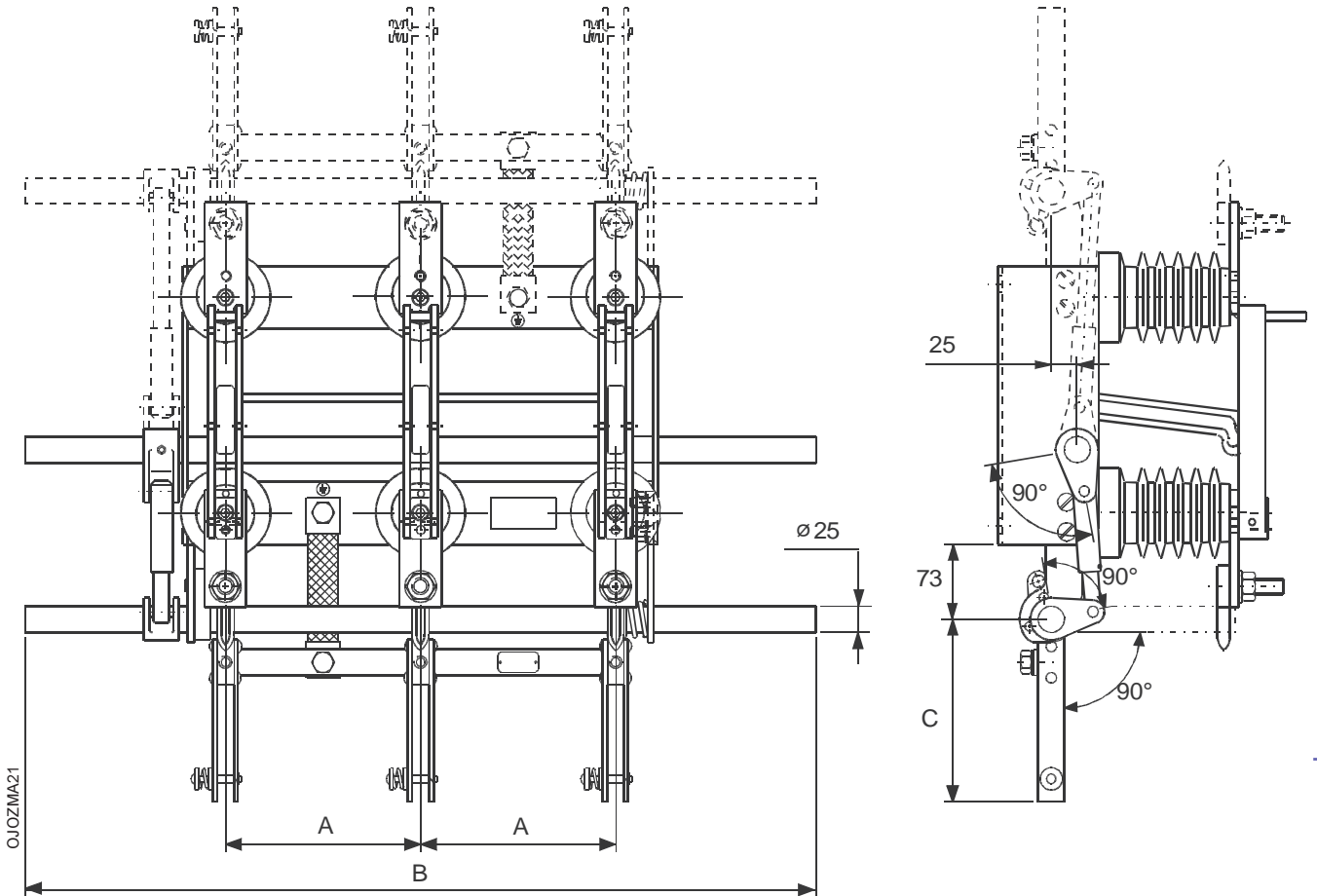

Earthing knife type	Disconnecter type	A	B	C	kg	Note
OJO-ZMA 10	OJON 3-10/630	185	750	173	9,0	When ordering the position of the earthing knife is to be stated (above or below).
OJO-ZMA 38	OJON 3-24 A 630	255	1090	258	10,1	

Provided by Northeast Power Systems, Inc.  
www.nepsi.com

# Disconnecter control

## Dimension drawings

### Operating arm

**YASKA 25**

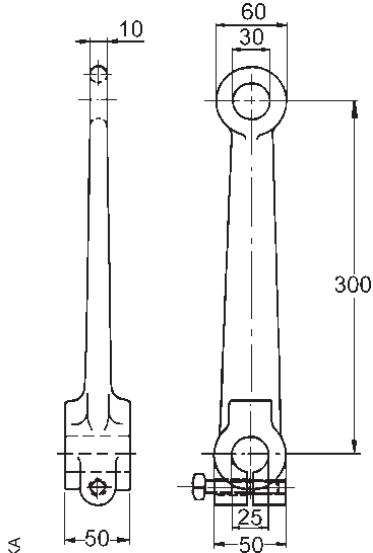

YASKA

Weight: 0.9 kg

### Operating rod

**NWA-ZS 5**

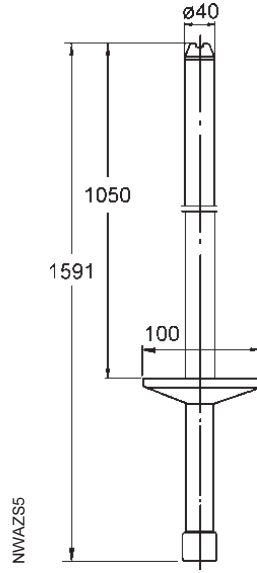

Weight: 1,5 kg

### Operation hook

**NWA-ZH 6**

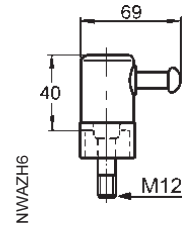

**NWA-ZS 6**

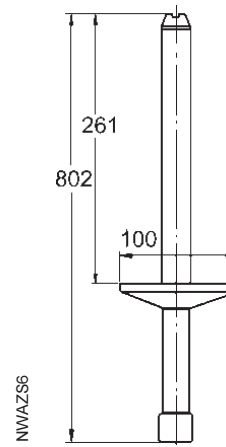

Weight: 0,9 kg

### Operating handle

**OJO-ZAK\_**

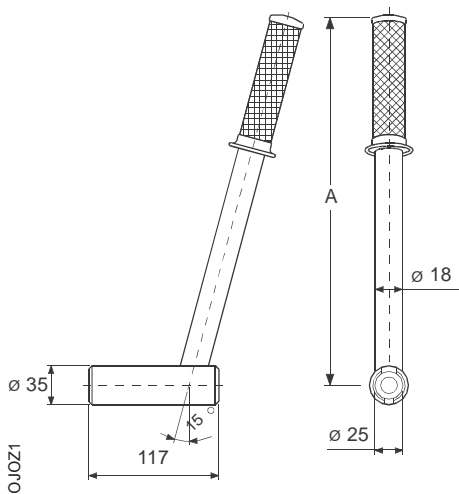

OJOZ1

Type	A	Weight kg
<b>OJO-ZAK 1</b>	330	1,2
<b>OJO-ZAK 2</b>	500	1,6

### Operating handle

**UEKO-ZK 1**

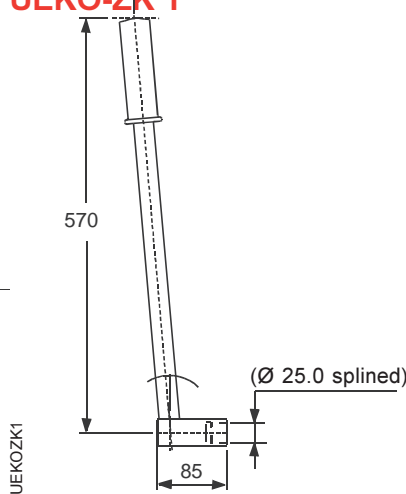

UEKOZK1

### Angle link

**YAEWK 3**

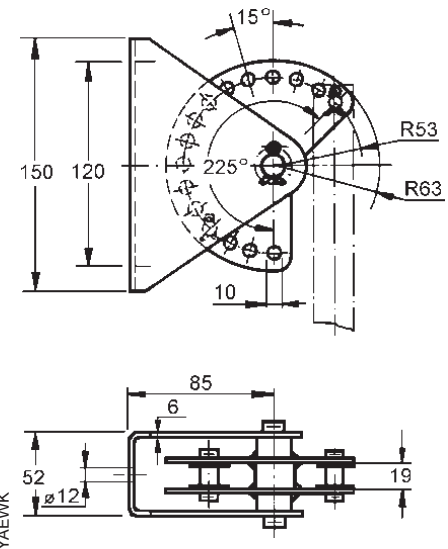

YAEWK

Weight: 1,8 kg

# Auxiliary switches

## Dimension drawings

### Auxiliary switch

#### OFC-ZA 1

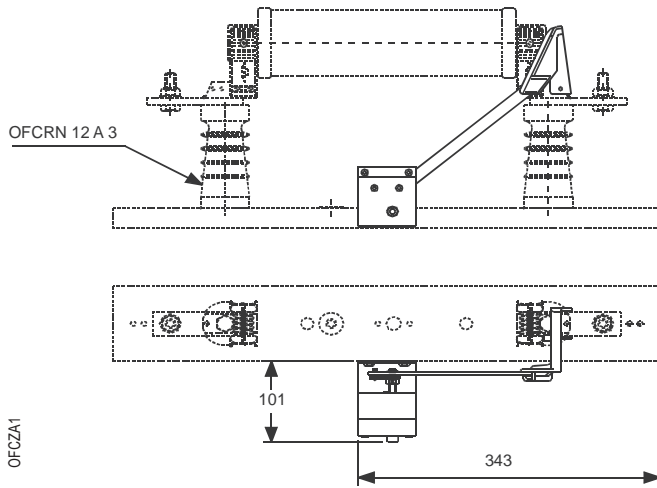

### Auxiliary switch

#### OFC-ZA 2

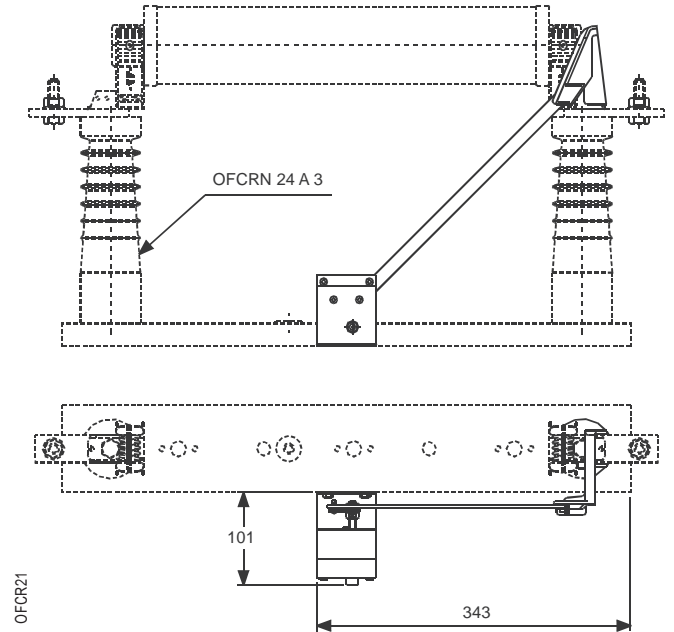

### Auxiliary switch

#### OLAN-AL 1

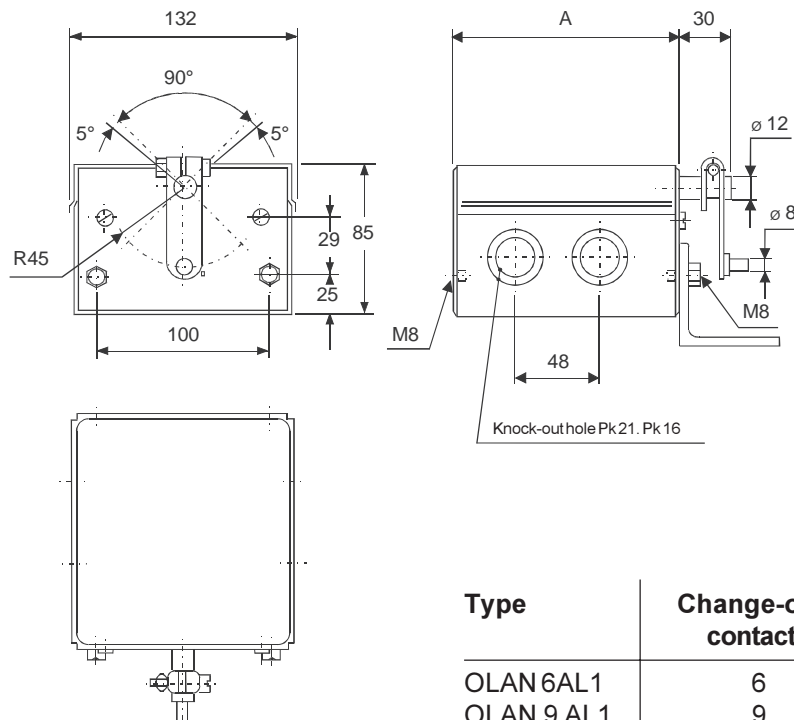

Type	Change-over contacts	A	Weight kg
OLAN 6AL1	6	136	1,5
OLAN 9 AL1	9	172	1,8

# Methods of mounting

## Dimension drawing

### Intermediate rod

#### OJ-ZDU 3 x 2000

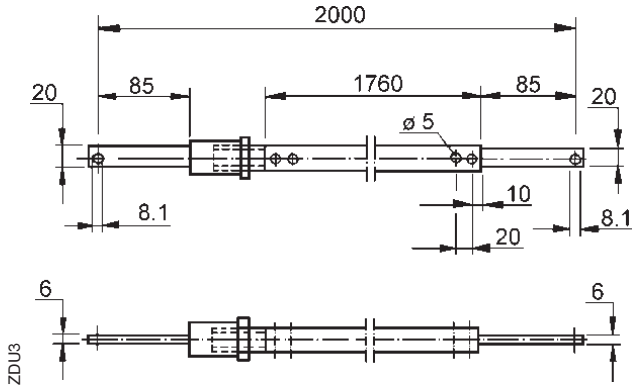

Adjustment margin  $\pm 15$  mm

Weight: 1,6 kg

### Intermediate rod

#### OJ-ZDU 4 x 2000

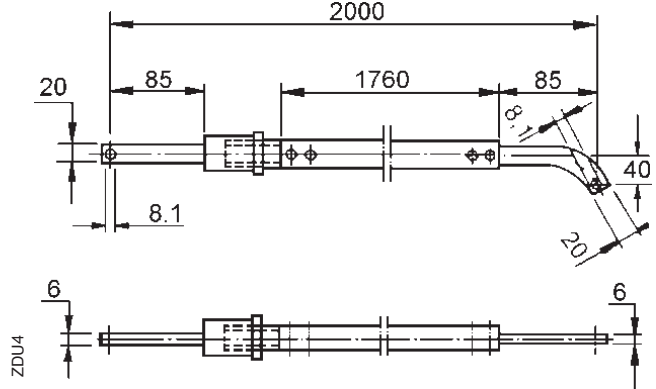

Adjustment margin  $\pm 15$  mm

Weight: 1,7 kg

### Auxiliary switch support (right)

#### OLAN-ZT 4

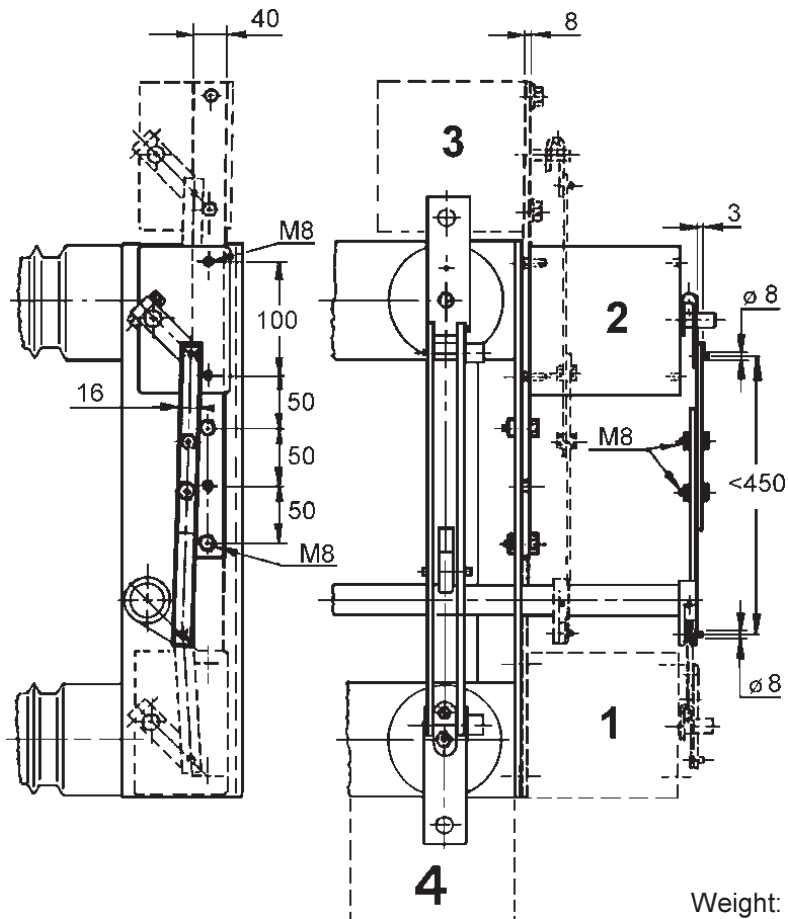

ZT4

If the mounting position is not mentioned it is fitted in position 4.

Weight: 0,8 kg

# Methods of mounting and interlocking

## Dimension drawings

### Adjustable lever

#### YAWAS 6

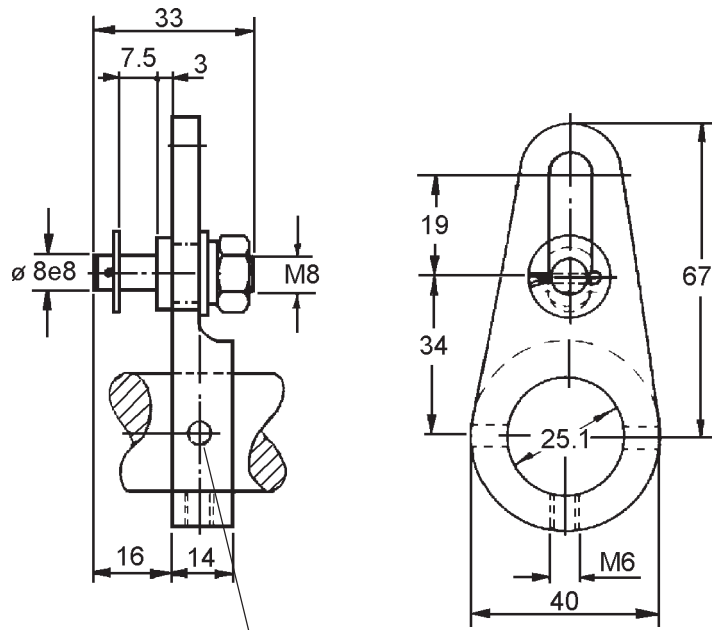

To be drilled when fitting  $\varnothing 5^{+0}_{+0,1}$

Weight: 0,8 kg

### Locking device

#### OJO-ZE\_

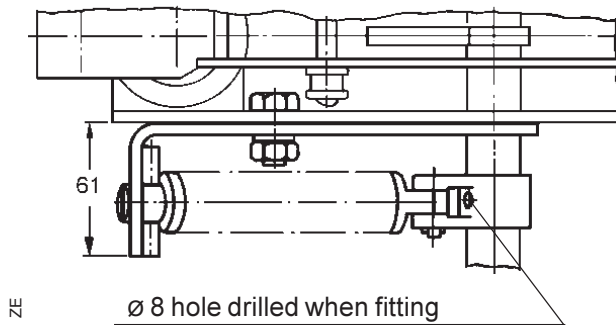
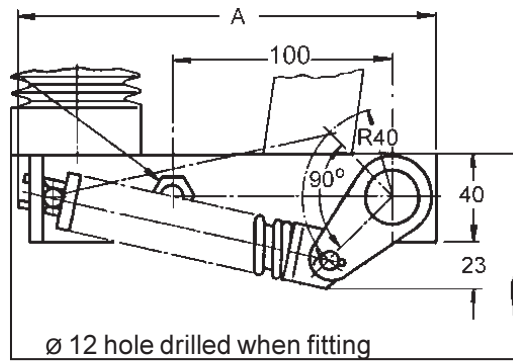

Type	A mm	Weight kg
OJO-ZE1	187	1,1
OJO-ZE2	237	1,3

YAWAS

Provided by Northeast Power Systems, Inc.  
www.nepsi.com

# Locking

## Dimension drawing

### Locking coil

#### OJO-ZLA3

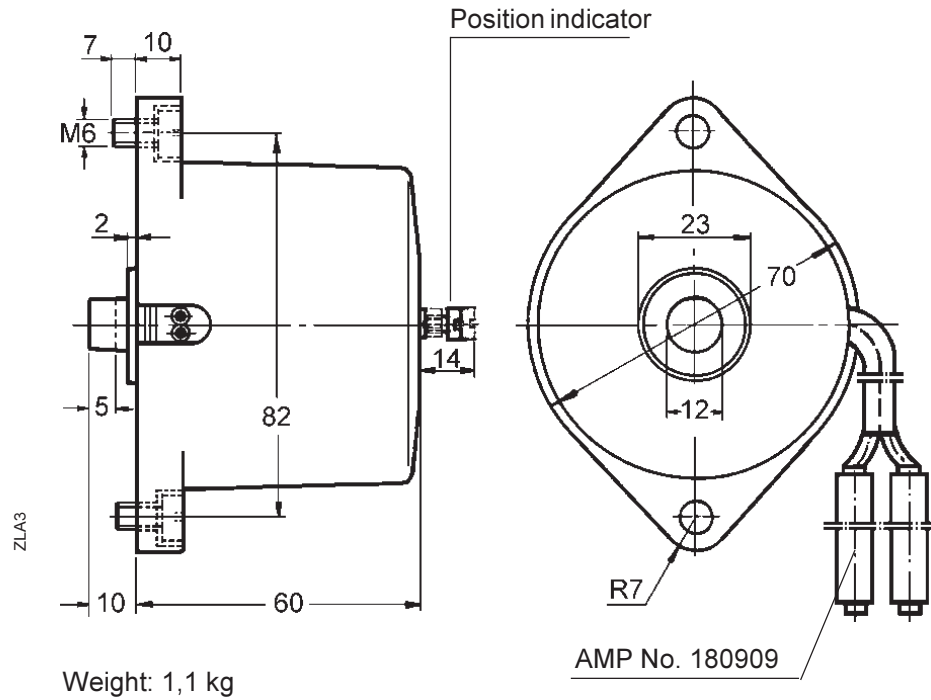

### Locking coil

#### OJO-ZLA6

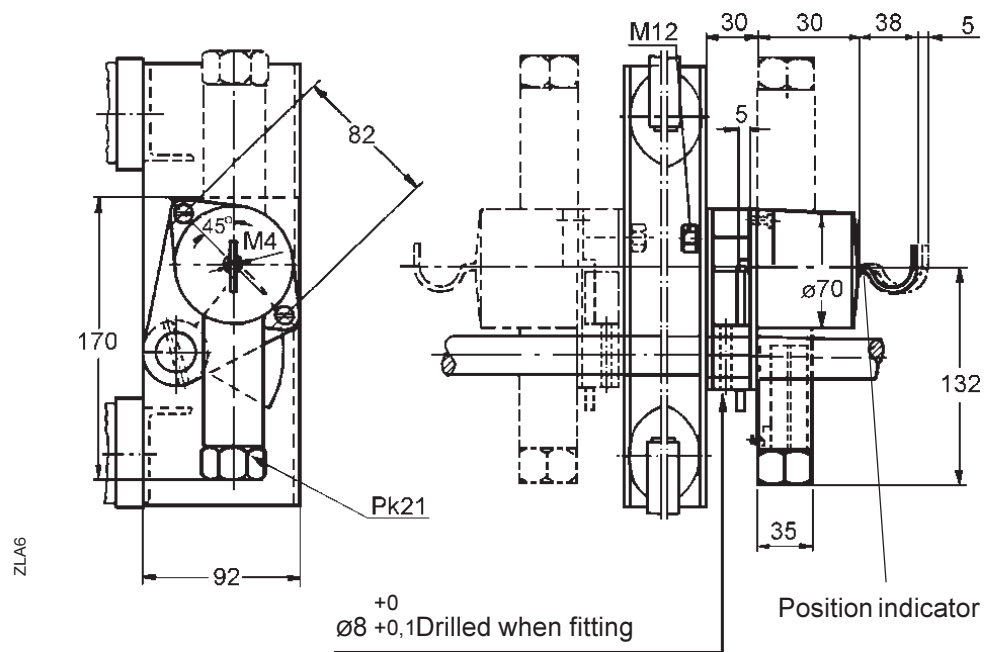

Incoming cable gland can also be turned upwards.

Weight: 2,3 kg

# Locking

## Dimension drawings

### Locking coil

#### UEKO ZL1

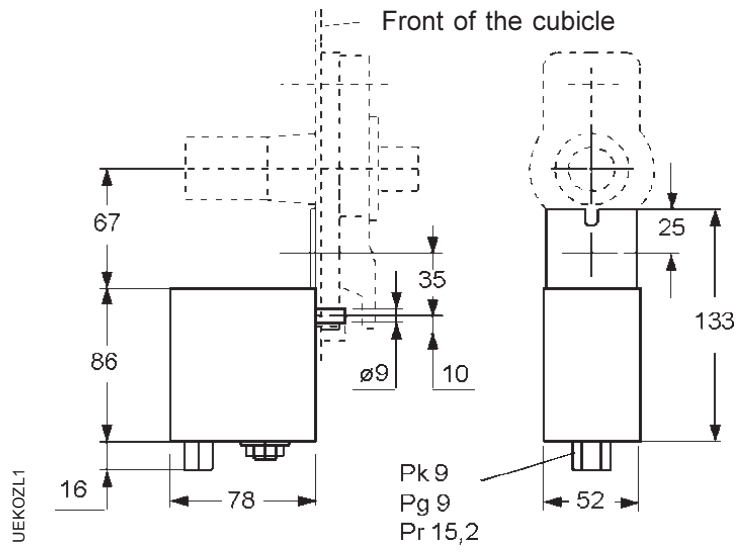

# Extension bushing and support bearing

## Dimension drawings

### Extension bushing

OJE-ZAA 25

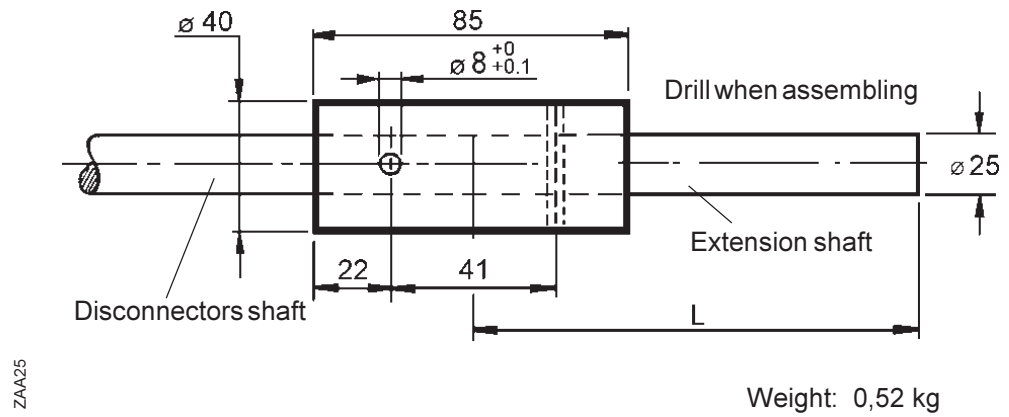

2 pcs spring pins included.

### Support bearing

OJO-ZU 3

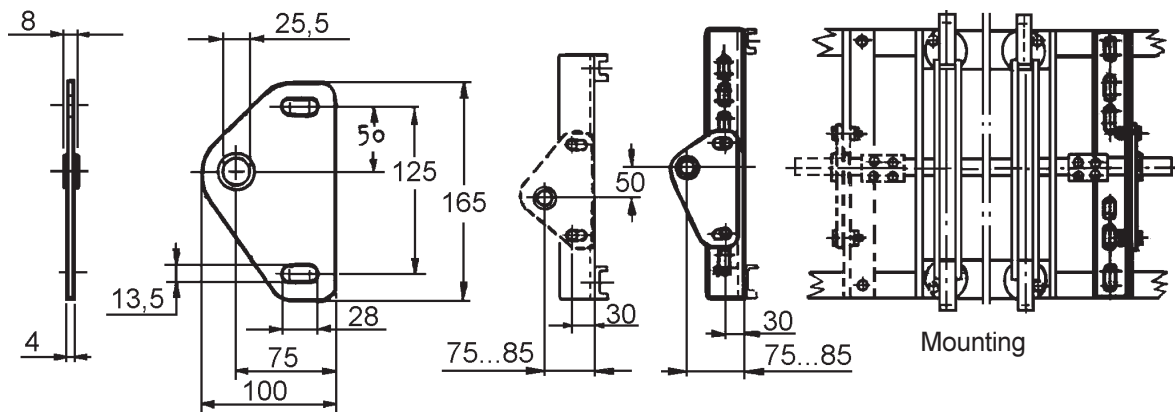

To be used for 10...24 kV OJON-disconnector extension shaft support bearing.

Angle iron not included.

Weight: 0,35 kg



## Fuse base for indoor use

### Dimension drawing

#### Fuse base OFCRN 12 A 3

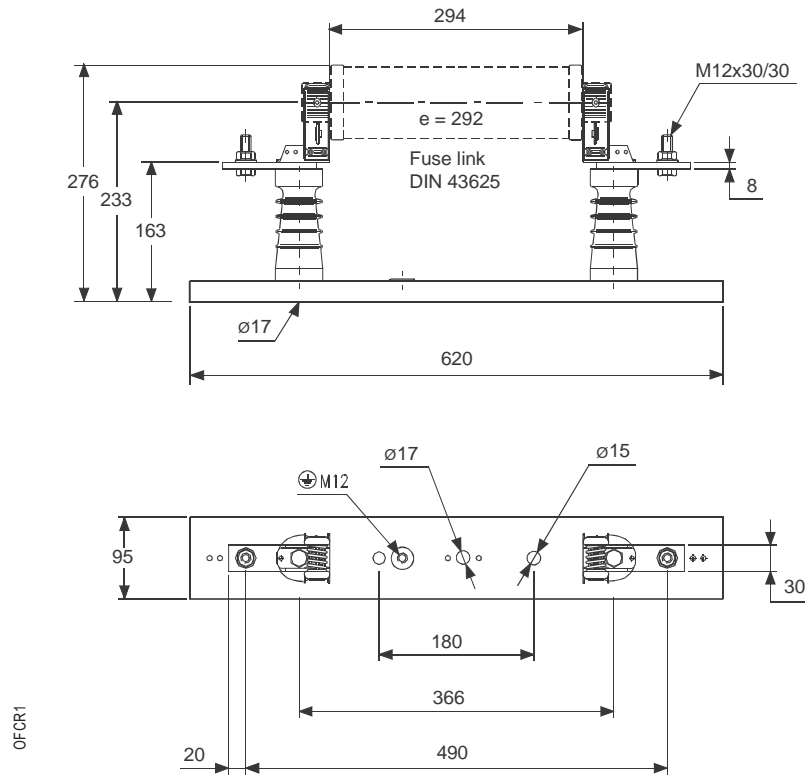

By moving one insulator 3,6/7,2 kV  $e = 192$  mm fuses can be fitted.  
The fuse base can be fitted with a blown fuse auxiliary contact, see page 27.  
The auxiliary switch is one NC contact.

#### Fuse base OFCRN 24 A 3

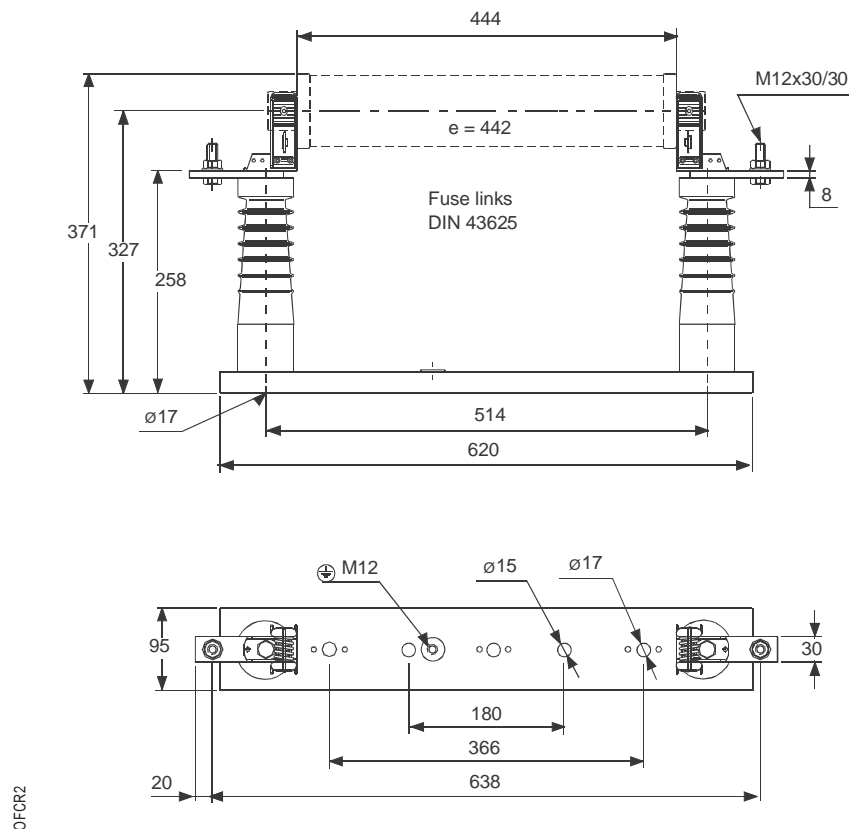

# Fuse base for indoor use

## Dimension drawing

### Fuse base

### OFCRN 36 A 3

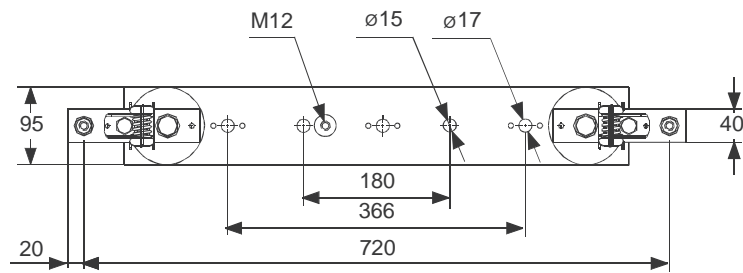
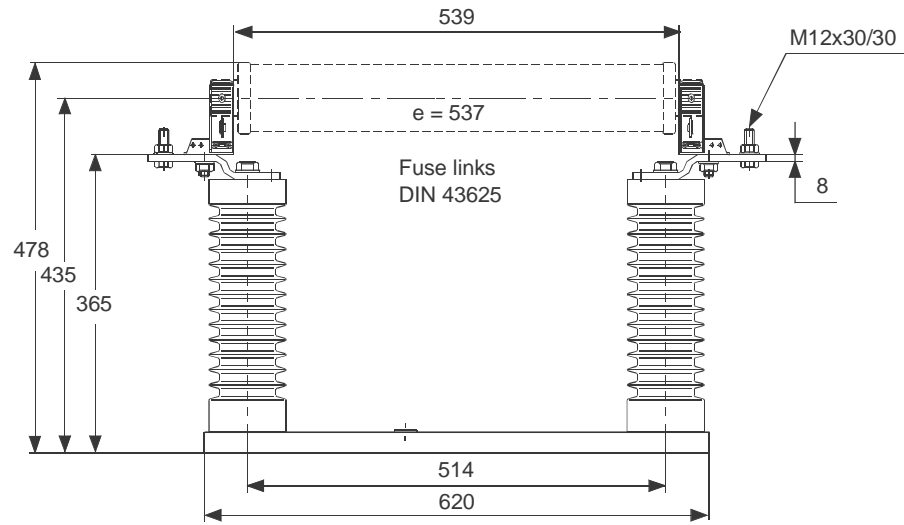

OFCR3

# Manual operating mechanism

## Dimension drawing

### Manual operating mechanism

#### OJO-ZA 1

### Drilling the front plate

For removing the interlocking coil we recommend a covered hole of 100 mm diameter for service access.  
Diagram for cover plate fixing with 8 mm holes.

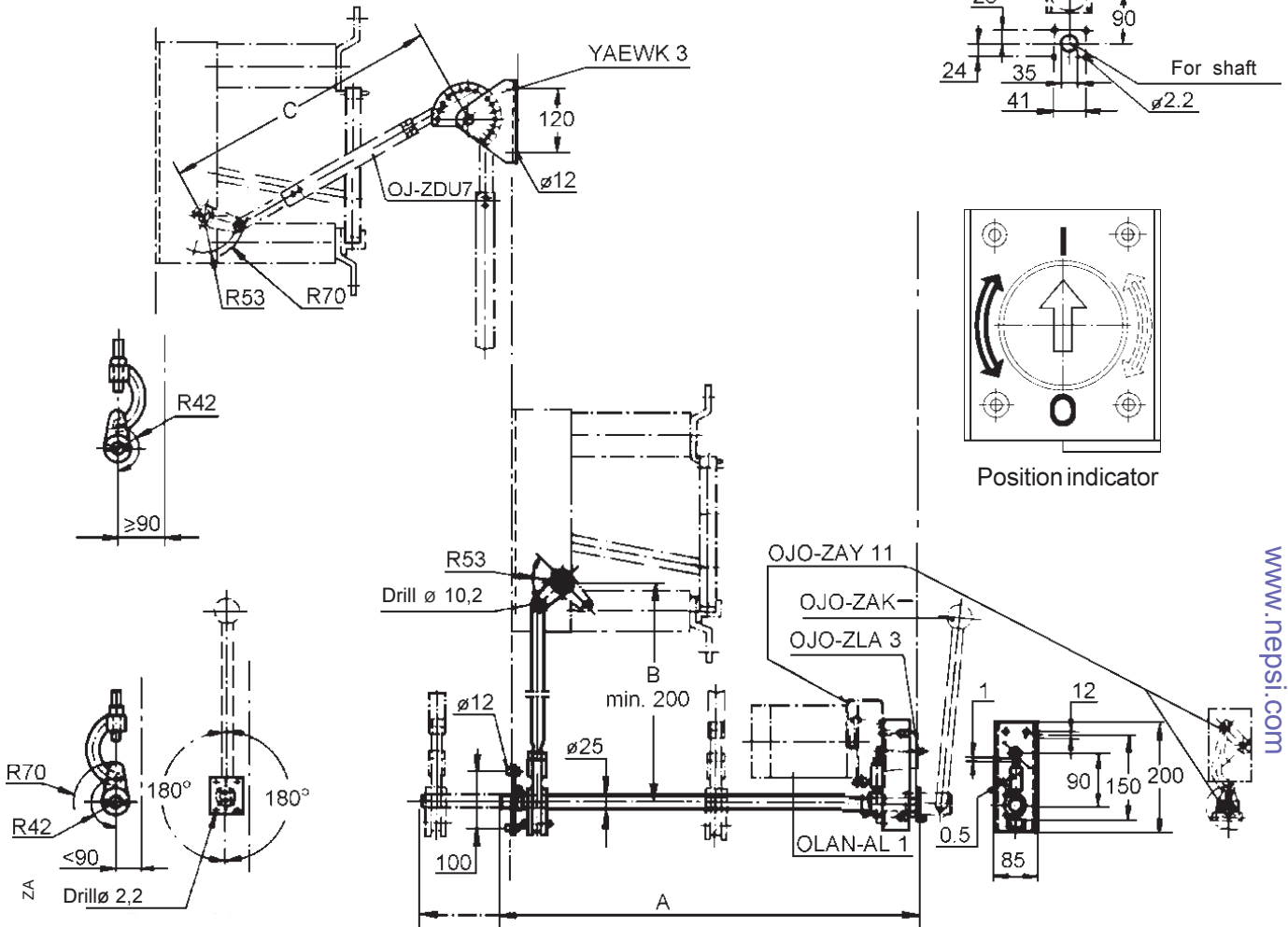

Provided by Northeast Power Systems, Inc.  
[www.nepsi.com](http://www.nepsi.com)

### Manual operating mechanism

#### UEKO 2C3

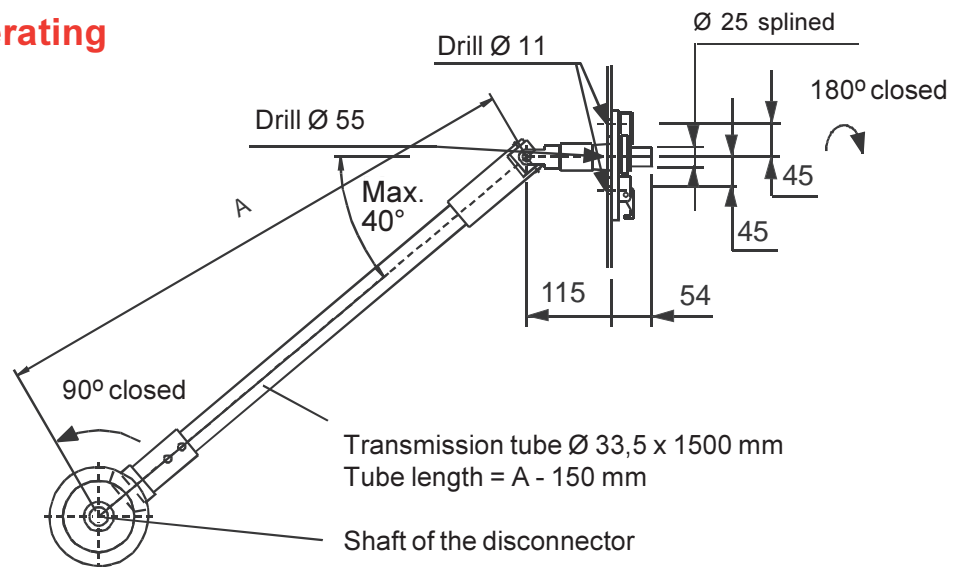

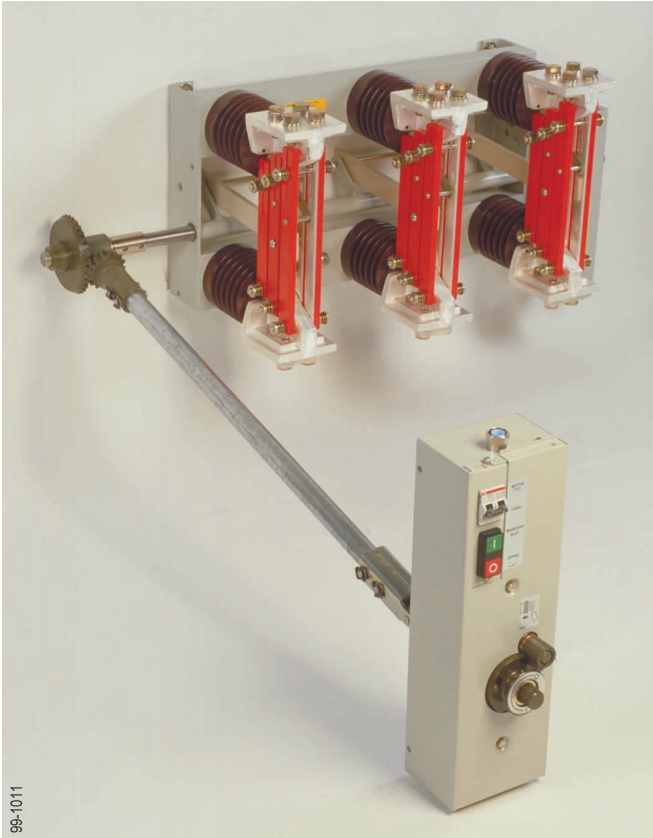

**Motor operating mechanism UEMC 40 A, B ja D -types mounted on the front of the cubicle.**

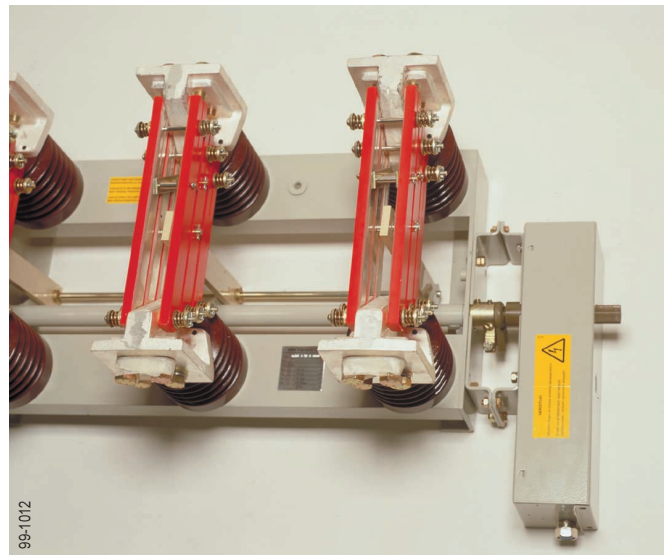

**Motor operating mechanism UEMC 40 K6 types mounted on the body of the disconnector.**

Provided by Northeast Power Systems, Inc.  
[www.nepsi.com](http://www.nepsi.com)



**Apparatus and Switchgear Business Unit**  
 P.O.Box 613, FIN-65101 Vaasa, Finland  
 Phone: +358 10 22 4000  
 Fax: +358 10 22 44661



Ykkös-Offset Oy  
 3000, 99-10  
 OJON 4 GB 99-10